

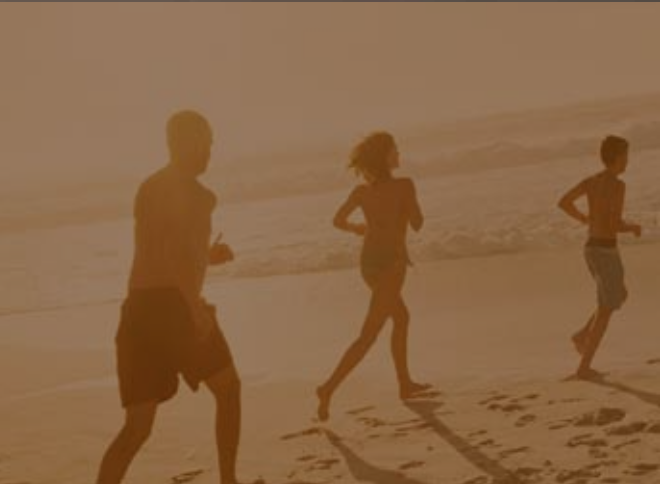

Jeep[®]

GRAND
CHEROKEE





THE MOST BEAUTIFUL OF ADVENTURES HAS BEGUN. A UNIQUE AND DETAILED DESIGN MELTS WITH AN ENTIRELY MODERN CHARACTER. THE RESULT: YOU ARRIVE AT THE PINNACLE OF LUXURY, APPOINTED WITH ADVANCED AMENITIES AND FULLY REALISED JEEP® BRAND CAPABILITY. THE TIME IS NOW TO MAKE EACH MOMENT GRAND.







CONTENTS

+ LAREDO	05
+ LIMITED	09
+ OVERLAND	11
+ CAPABILITY	16
+ RIDE & HANDLING	17
+ ENGINES	22
+ SAFETY & SECURITY	23
+ UCONNECT™	25
+ GENUINE ACCESSORIES	27



LAREDO

05

LAREDO

LAREDO TAKES TO THE ROAD WITH THE HUSHED RIDE OF A STEALTH MACHINE, ALL THANKS TO THE DOUBLE-DASH CONSTRUCTION AND SURROUNDING ACOUSTIC GLASS. STANDARD INTERIOR AMENITIES ABOUND WITHIN IT'S SOFT-TOUCH INTERIOR. CARRY THE KEY FOB IN YOUR POCKET, PURSE OR BRIEFCASE AND THE STANDARD KEYLESS ENTER-N-GO FEATURE AUTOMATICALLY UNLOCKS THE DOORS AND ALLOWS YOU TO START THE ENGINE WITHOUT USING THE KEY.





1 **DUAL-ZONE AUTOMATIC TEMPERATURE CONTROL (ATC).** + An advanced infrared sensing device automatically checks the temperature of the driver and front passenger, as well as the air temperature inside the cabin to create a customised, comfortable environment.

2 **SMARTBEAM™ HEADLAMPS WITH AUTO-LEVELLING.** + Brighter, better, safer. Bi-Xenon High Intensity Discharge (HID) headlamps with headlamp washers shine up to three times brighter than regular headlamps. Standard auto-levelling keeps lamps focused down on the road ahead.

3 **ALL-INVITING.** + The leather-covered tilt/telescoping steering wheel with cruise control, EVIC and audio controls are standard. Uconnect™ Phone comes standard for hands-free communication.

4 **ELECTRONIC STABILITY CONTROL⁽¹⁾ (ESC).** + A standard feature that enhances driver control and helps maintain vehicle stability at all times, over all terrain.

(1) No system, no matter how sophisticated, can repeal the law of physics or overcome careless driving actions. Performance is limited by available traction, which snow, ice and other conditions and other conditions can affect. When the ESC warning lamp in the speedometer flashes, the driver needs to use less throttle and adapt driving behavior to prevailing road conditions. Always wear your seat belt.

ART IN MOTION.







1 SCULPTED AND ATHLETIC. + Grand Cherokee's muscular profile speaks volumes about its capabilities. Its presence is at once contemporary and timeless. All-weather capability comes with your choice of two 4x4 systems, each engineered with exclusive Jeep® brand strength.

2 THE RIGHT LIGHT. + Bi-Xenon High Intensity Discharge (HID) headlamps have SmartBeam™ auto-dimming technology that automatically adjusts high beams to the surrounding sources of light.

3 CARGO HOLD. + Configure your interior to suit the situation. The 60/40 split-folding rear seats fold flat to reveal a large rear cargo area that offers up to 1,554-litres of room for gear.

4 ADVANCED TECHNOLOGY INFUSION. + Limited's leather-trimmed interior is brimming with standard technological advancements, including a Media Centre outfitted with the safe and convenient voice-activated Uconnect™ Phone for up to seven Bluetooth® compatible phones. Heated seats warm passengers in the first and second rows.



Learn more on page 25.



1

LIMITED



10

LIMITED

LIMITED PUTS POWER BEHIND AN EFFICIENT PERFORMANCE, EARNING NODS FOR POWER AND DRIVING RANGE. THE STANDARD 4WD QUADRA-TRAC II® 4x4 SYSTEM AND SELETERRAIN® VEHICLE MANAGEMENT SYSTEM HELP TO GAIN PASSAGE, WHETHER YOU CHOOSE TO TRAVEL ON ROADS COVERED WITH MUD, SAND OR ROCKS. THE AVAILABLE QUADRA-LIFT® AIR SUSPENSION SYSTEM ALLOWS YOU TO LOWER GRAND CHEROKEE 38 MM BELOW NORMAL RIDE HEIGHT FOR EASIER ENTRY, EXIT AND LOADING.



2



3



4





OVERLAND®

OVERLAND ARRIVES WITH SUPREME GRACE, EQUIPPED WITH STANDARD LUXURY AND ULTIMATE CAPABILITY. CHOOSE FROM TWO 4x4 SYSTEMS FOR WORRY-FREE TRAVEL THROUGH RAIN, MUD OR SAND. OVERLAND COMES STANDARD WITH THE 5.7-LITRE V8 ENGINE DELIVERING HIGH PERFORMANCE AND TOWING CAPACITY, GIVING YOU 259 KW OF POWER TO TOW UP TO 3,500 KG WHEN PROPERLY EQUIPPED.





1 DETAILED DIFFERENCE. + Every surface within reach is soft to the touch. Ash Burl real wood trim, chrome details and stitching accents offer exceptional craftsmanship.

2 A SYSTEMISED, REVOLUTIONARY RIDE. + The Quadra-Lift® Air Suspension System gives you ultimate control of your suspension system, along with a serious lift in performance and capability. A standard feature on every Overland.®

3 A LUXURIOUS POSITION. + Overland's standard combo, CommandView® dual-pane panoramic sunroof and premium Nappa leather-trimmed interior, keep the view fresh. (Light Frost Beige interior with Medium Olive Ash Burl real wood trim).

4 LEATHER-WRAPPED GLORY. + An eight-way power driver's seat with power lumbar control is standard. It sits before a heated, leather-wrapped steering wheel and a leather-wrapped and stitched instrument panel.





YOU HAVE
ARRIVED.





IT'S A 4x4 WORLD OUT THERE.



CONFIDENCE TO GO ANYWHERE, DO ANYTHING[®] IS BORN AND BRED IN EVERY JEEP[®] BRAND TRANSFER CASE. JEEP OFF-ROAD READY 4x4s PERFORM TO RIGOROUS STANDARDS IN FIVE CATEGORIES: ARTICULATION, MANEUVERABILITY, TRACTION, GROUND CLEARANCE AND WATER FORDING. KEEP MOVING FORWARD, NO MATTER WHAT LIES AHEAD.

CHOOSE YOUR 4x4 SYSTEM

QUADRA-DRIVE[®] II puts ultimate capability at hand with its Electronic Limited-Slip Differential (ELSD) that transfers 100 percent of torque to the wheel(s) with traction (packaged with Off-Road Group).

QUADRA-TRAC II[®] offers All-speed Traction Control (ASTC) to help keep you on course. If wheel slippage occurs, up to 100 percent of the available torque can be routed to the axle with the most traction. Low-range provides rock-crawling prowess (standard on all models).

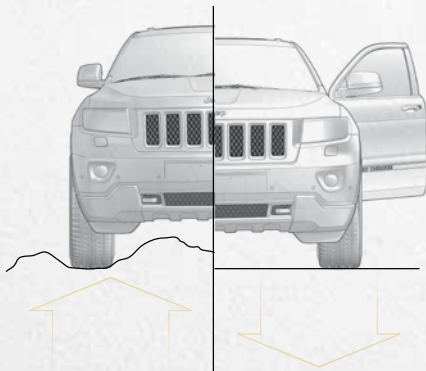

QUADRA-LIFT[®]

A revolutionary system that gives you ultimate control of your suspension. It allows you to easily raise your vehicle higher, up to 104 mm of additional ground clearance, for a maximum ground clearance of 271 mm above ridges and rocks. Or lower it 38 mm for easier entry, exit and loading. The system also raises the vehicle from back to front to help keep headlights safely focused downward at the road ahead. Available.

SELEC-TERRAIN[®]

Optimal on and off-road traction is instantly at hand. Five selectable settings electronically coordinate 12 different vehicle management systems to adjust your traction control to match the road ahead. Whether you're caught in thick muddy tracks or climbing backcountry hills, you'll have the confidence to bravely meet all challenges. Standard.





1



2



3



- 1 INDEPENDENT SUSPENSION.** + The front and rear suspension and their isolated cradles help absorb troubling bumps as if they were never in your way.
- 2 UNIFRAME CONSTRUCTION.** + Renowned ultra-high-strength Jeep® engineered UniFrame construction incorporates high-strength steel, adding substantial body stiffness and reduced road noise, giving you one of the quietest rides available in an SUV.
- 3 SMOOTH STEERING.** + The electrohydraulic power steering provides the natural, smooth feel of a sophisticated conventional hydraulic power steering system while simultaneously helping to improve efficiency by using electric power instead of drawing power from the engine.



REDEFINE THE RIDE.

YOU'RE PROTECTED FROM THE WORLD AND ITS WORRIES, THANKS TO GRAND CHEROKEE'S ALL-WEATHER CAPABILITY AND SMOOTH RIDE. JEEP® ENGINEERS DEVOTED ENDLESS HOURS OF DETAILED ATTENTION TO ENSURE GRAND CHEROKEE'S FIT, FINISH AND DURABILITY RESULTING IN HANDLING THAT FEELS CLOSER TO A LUXURY SEDAN THAN A FORMIDABLE SUV.







ROAD MANNERS TO BRAG ABOUT.

When they ask about Grand Cherokee's smooth, refined ride; the hushed, acoustically sound cabin; the easy, controlled cornering, answers come easy. The isolated cradles of the independent front and rear suspension help provide added cushioning not unlike the priciest luxury sedans. The double-dash construction and the premium insulation help stop road noise in its tracks. The exacting fit and finish manufacturing methods are designed to create near-perfect assemblies. It all adds up to an on-road experience that rivals many of the world's most luxurious sedans.





SMART. STRONG.

POWER YOUR GRAND CHEROKEE WITH EITHER THE STANDARD 3.6-LITRE PENTASTAR® V6 ENGINE WITH VARIABLE VALVE TIMING (VVT), OR THE AVAILABLE 5.7-LITRE V8 ENGINE WITH IT'S FUEL SAVER TECHNOLOGY AND VVT. BOTH ARE ENGINEERED TO DELIVER THE CAPABILITY YOU EXPECT FROM A JEEP® VEHICLE. THEY ALSO COME PACKAGED WITH EFFICIENCIES THAT HELP PUT MORE KILOMETRES AND SCENERY BETWEEN FILLING-UP. INGENUOUS, INDEED.

PENTASTAR 3.6-LITRE V6 ENGINE.

The standard Pentastar cranks out enough power to tow up to 2,268 kg when properly equipped. Dual overhead camshafts (DOHC) and structural refinements allow it to achieve high efficiency. Variable Valve Timing (VVT) helps make the most of precious fuel, at any speed.

210 | **347**
kW OF POWER | N.m OF TORQUE

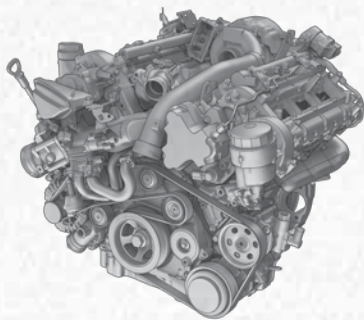
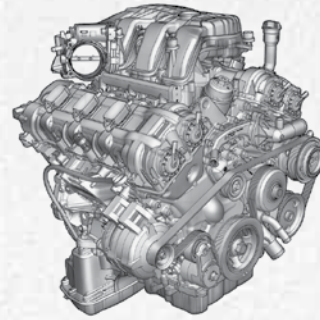

3.0-LITRE TURBO DIESEL ENGINE.

Opt for the available 3.0-litre turbo diesel engine, an efficient performer that utilises a highly pressurised fuel rail connected to piezo injectors that help fuel burn more completely. A Variable Geometry Turbocharger and an integrated diesel particulate filter help reduce fuel consumption, exhaust emissions and engine noise.

177 | **550**
kW OF POWER | N.m OF TORQUE

5.7-LITRE HEMI® V8 ENGINE.

This available workhorse churns out power and torque, and is strong enough to tow up to 3,500 kg. The Multi Displacement System (MDS) revamps this eight-cylinder, 259 kW powerhouse during cruising speeds, turning it into a four-cylinder model of efficiency. It can seamlessly alternate between the higher fuel economy of the four-cylinder mode when less power is needed yet, when you step on the pedal, all eight cylinders quickly roar back to life. Performance is always stellar.

259 | **520**
kW OF POWER | N.m OF TORQUE

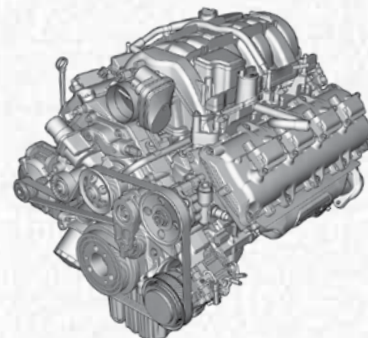



GUARDIAN HERO.

PEACE OF MIND TAKES YOU FAR. JEEP® GRAND CHEROKEE IS ENGINEERED TO PERFORM HEROICALLY IN ALL DRIVING CONDITIONS. YOU'LL FEEL THE STRENGTH OF ITS REINFORCED STRUCTURE, SHELTERED WITHIN AN ENVIRONMENT THAT SERVES YOU WELL. GO FORWARD, EMPOWERED WITH THE INSPIRED CONFIDENCE OF GRAND CHEROKEE.



ELECTRONIC STABILITY CONTROL (ESC).⁽¹⁾

A vehicle-wide network of safety sensors provide instant aid when they detect that you're veering off your intended path. ESC immediately goes into action when needed.

SMARTBEAM™ HEADLAMPS WITH AUTO-LEVELLING.

Brighter, better, safer. Bi-Xenon High Intensity Discharge (HID) headlamps shine up to three times brighter than regular headlamps. An auto-leveling feature keeps lamps focused down at the road ahead. Headlamp washers keep front lamps clean and clear.

TRAILER SWAY CONTROL (TSC).

Crosswinds and traffic hold no sway over you and your payload. As part of ESC, TSC helps keep you and the gear you are towing, safely on course and under control.

RAIN-SENSING WIPERS AND RAIN BRAKE SUPPORT.

Storm clouds hold little influence over your daily drive. Front wipers activate when raindrops are detected and a smart brake system helps dry the brake rotors on wet roads.

PARKSENSE® FRONT AND REAR PARK ASSIST AND PARKVIEW REVERSING CAMERA.⁽²⁾

Reverse in and out with grace. These systems help bring previously hidden rear objects to your attention, either on-screen or with an audible warning, in good time to react (ParkSense not available on Laredo).

ADAPTIVE CRUISE CONTROL (ACC).⁽³⁾

ACC automatically adjusts cruising speed to maintain a preset distance between your Grand Cherokee and the crowd ahead (standard on Overland).





ACTIVE HEAD RESTRAINTS⁽⁴⁾ A standard and effective safety feature that can help stave off neck injuries. Restraints automatically react and adjust to help provide protection during rear-impact collisions.

FORWARD COLLISION WARNING (FCW) Even the most attentive drivers will appreciate the help of this warning system. Approach another vehicle too rapidly and Grand Cherokee lets you know so you can take appropriate action (standard on Overland).

A SAFE, SECURE AIR BAG SYSTEM⁽⁵⁾ Standard full-length side-curtain, seat-mounted side-thorax, and advanced multi-stage front air bags all work in tandem to help provide protection.

ELECTRONIC ROLL MITIGATION (ERM). If things get rough, Grand Cherokee's ERM takes immediate action to help you maintain stability and remain under control.

HILL DESCENT CONTROL (HDC) AND HILL START ASSIST (HSA). These systems are always at your beck and call when you need to get safely around the corner or up and down the mountain.

ANTI-LOCK BRAKE SYSTEM (ABS). The benefits of ABS on slippery, wet roads are widely known. This advanced system knows when you're driving over rough terrain and adjusts accordingly to help keep you in optimum control.

SENTRY KEY[®] ENGINE IMMOBILISER. A unique, embedded key code matched only to your vehicle helps keep your Grand Cherokee safely where it belongs.

BLIND SPOT MONITORING⁽⁶⁾ AND REAR CROSS-PATH DETECTION SYSTEMS⁽⁶⁾ These available sentry systems constantly monitor the space between you and other drivers. When a side or rear blind spot is encroached, you're notified via illuminated icons on sideview mirrors or an audible chime (standard on Overland).

(1) No system, no matter how sophisticated, can repeal the law of physics or overcome careless driving actions. Performance is limited by available traction, which snow, ice and other conditions and other conditions can affect. When the ESC warning lamp in the speedometer flashes, the driver needs to use less throttle and adapt driving behavior to prevailing road conditions. Always wear your seat belt. (2) Always check entire surroundings before reversing. (3) ACC is a driver convenience system, not a substitute for driver involvement. The driver must remain aware of traffic conditions and be prepared to use brakes to avoid collision. (4) Always sit properly with the head restraint properly adjusted. Never place anything in front of the head restraint. (5) Always sit properly in the seat with the seat belt fastened. Always observe the passenger air bag indicator light to determine if the Occupant Classification System (OCS) is appropriate. Children under 12 years and under should always be in the backseat correctly using an infant or child restraint system or the seat belt positioned correctly for the child's age and weight. (6) Always check visually for vehicles prior to changing lanes.





INFORMED AND WELL-CONNECTED.

STAY IN TOUCH WITH THE PEOPLE, MUSIC AND DEVICES THAT MATTER MOST. UCONNECT™ IS AN INTUITIVE HUB FOR ALL YOUR MEDIA I.E MOBILE PHONE, NAVIGATION SYSTEM AND MP3 PLAYER. YOU'LL STAY WELL CONNECTED, INFORMED, ENTERTAINED AND FOCUSED ON DRIVING WITH THIS USER-FRIENDLY SYSTEM.



ENTERTAINMENT. Manage all of your media and access your audio in six different ways. Get the sound going via CDs/DVDs, MP3s, remote USB port, auxiliary input jack, hard disc storage, Voice Command⁽¹⁾ and Bluetooth® streaming audio.



PHONE. Uconnect Phone⁽²⁾ is an in-vehicle, voice-activated communication system that allows you to talk on your Bluetooth® compatible phone virtually hands-free. This clever system is also smart enough to synchronise with your Bluetooth compatible phone's address book with up to 1,000 entries.



NAVIGATION. Enjoy safe travels with the available GPS navigation, providing voice guidance and visual display. It can also locate nearby petrol stations, restaurants, shopping, hospitals, or points of local interest (when equipped).



VOICE COMMAND. It simplifies driving by letting you keep your eyes on the road and your hands on the wheel. Use your voice to select radio stations and make calls. Select navigation⁽³⁾ destinations and record voice memos. This smart system technology can also be trained to better recognise your voice and can understand commands in English, Dutch, French, German, Italian and Spanish.

(1) Requires Uconnect Phone. (2) Must use Bluetooth compatible phone. (3) Never program while driving. GPS mapping may not be detailed in all areas or reflect current road regulations. See dealer for details.



MEDIA CENTRE 730N CD/DVD/HDD/NAV RADIO. Go anywhere, hear everything with this advanced multimedia system. Hands-free communication lets you safely talk on the phone, text, or operate the navigation/radio. It arrives loaded with a 40GB hard drive to store all of your media.



GENUINE JEEP® ACCESSORIES.

THERE'S NO BETTER WAY TO PERSONALISE YOUR GRAND CHEROKEE THAN TO ADD GENUINE JEEP ACCESSORIES BY MOPAR. DON'T SETTLE FOR ANYTHING OTHER THAN GENUINE AS ALL ACCESSORIES FEATURE THE FIT, FINISH AND FUNCTIONALITY SPECIFICALLY DESIGNED FOR YOUR VEHICLE.

GENUINE JEEP® ACCESSORIES BY MOPAR

SPORT. + No matter what adventure you seek, you'll want to add to the sport of it all with durable and convenient Mopar carriers.

PROTECTION. + Safeguard your vehicle with parts and accessories made precisely for the protection and security of your ride.

STYLE. + Select from a palate of attractive accessories designed to enhance your vehicle's appearance and express your individual taste.

INNOVATION. + The latest of Mopar technology can add significant value to your ride.





- 1 DOOR ENTRY GUARDS. + Front door sill guards feature the Grand Cherokee logo. Compatible with illuminated door sill guards. Set of four.
- 2 BLACK TUBULAR SIDE STEPS. + Mounted securely with corrosion resistant, electro-coated steel mounting brackets. No drilling required.
- 3 DOG BED CARGO MAT + Keep your favourite canine content while keeping your cargo area protected from dirt, drool and other messy situations.
- 4 TENT KIT. + Can be attached to the rear of your vehicle or used as a standalone tent.
- 5 ROOF MOUNT WATER SPORTS CARRIER. + Transports most kayaks, sailboards or surfboards with flat or curved hulls. Includes nylon latching and skip-resistant pads.
- 6 CHROME STYLING. + Add a touch of chrome to Grand Cherokee with the available mesh grille inserts, tubular side steps, mirror caps and exhaust tips.
- 7 ROADSIDE SAFETY KIT. + A valuable asset in a roadside emergency. Kit includes a triangle reflector, torch, tow rope, jumper cables and safety vest.







Chrysler Group FINANCIAL

CHOOSING THE RIGHT VEHICLE AND FINDING THE RIGHT FINANCIAL PACKAGE HAS BEEN MADE EASIER WITH CHRYSLER GROUP FINANCIAL.⁽¹⁾ AS YOU WOULD EXPECT, CHRYSLER GROUP FINANCIAL HAVE A RANGE OF FLEXIBLE PRODUCTS, TAILORED TO MAKE YOUR LIFE EASIER. WHETHER YOU ARE A PRIVATE PURCHASER OR YOU'RE CHOOSING ONE OF OUR VEHICLES FOR BUSINESS, CHRYSLER GROUP FINANCIAL HAVE A WIDE RANGE OF FINANCIAL PRODUCTS AND LEASE PRODUCTS. AFTER ALL, THE RIGHT CAR NEEDS THE RIGHT FINANCIAL PACKAGE TO COMPLEMENT YOUR LIFESTYLE.

(1) Chrysler Group FINANCIAL is a registered business name of Macquarie Leasing Pty Ltd ABN 38 002 674 982 (ML) who is the financier of these products. ML is not an authorised deposit-taking institution for the purposes of the Banking Act 1959 (Cth) and ML's obligations do not represent deposits or other liabilities of Macquarie Bank Limited ABN 46008 853 542. Macquarie Bank Limited does not guarantee or otherwise provide assurance in the respect of the obligations of ML.



All product illustrations and specifications are based upon current information at the time of publication approval. Although descriptions are believed correct, accuracy cannot be guaranteed. Chrysler Group LLC reserves the right to make changes from time to time, without notice or obligation, in prices, specifications, colours, materials and to change or discontinue models. See your dealer for details. Jeep, Grand Cherokee, Mopar, Overland, Quadra-Trac II, Quadra-Drive, Sentry Key, VES and the Jeep Grille are registered trademarks and Uconnect is a registered trademark of Chrysler Group LLC. Bluetooth is a registered trademark of Bluetooth SIG, Inc. iPod is a registered trademark of Apple, inc. Alpine is a registered trademark of Alpine Electronics, Inc. All rights reserved.

Printed in Australia SBWK2012 02/12

Jeep[®]