

Jeep[®]

User Guide



2012
Grand Cherokee
Includes SRT8

If you are the first registered retail owner of your vehicle, you may obtain a complimentary printed copy of the Owner's Manual, Navigation/Media Center Manuals or Warranty Booklet by calling 1-877-426-5337 (U.S.) or 1-800-387-1143 (Canada) or by contacting your dealer.

The driver's primary responsibility is the safe operation of the vehicle. Driving while distracted can result in loss of vehicle control, resulting in a collision and personal injury. Chrysler Group LLC strongly recommends that the driver use extreme caution when using any device or feature that may take their attention off the road. Use of any electrical devices such as cell phones, computers, portable radios, vehicle navigation or other devices by the driver while the

vehicle is moving is dangerous and could lead to a serious collision. Texting while driving is also dangerous and should never be done while the vehicle is moving. If you find yourself unable to devote your full attention to vehicle operation, pull off the road to a safe location and stop your vehicle. Some States or Provinces prohibit the use of cellular telephones or texting while driving. It is always the driver's responsibility to comply with all local laws.

Important:

This User Guide is intended to familiarize you with the important features of your vehicle. The DVD enclosed contains your Owner's Manual, Navigation/Media Center Manuals, Warranty Booklets, Tire Warranty and 24-Hour Towing Assistance (new vehicles purchased in the U.S.) or Roadside Assistance (new vehicles purchased in Canada) in electronic format. We hope you find it useful. Replacement DVD kits may be purchased by visiting www.techauthority.com. Jeep® is a registered trademark of Chrysler Group LLC. © 2012 Chrysler Group LLC.

TABLE OF CONTENTS

INTRODUCTION/WELCOME

Welcome From Chrysler Group LLC . . .	3
---------------------------------------	---

CONTROLS AT A GLANCE

Driver Cockpit	6
Instrument Cluster	8

GETTING STARTED

Key Fob	10
Remote Start	12
Keyless Enter-N-Go™	13
Theft Alarm	16
Seat Belt	16
Supplemental Restraint System (SRS) — Air Bags	17
Child Restraints	18
Front Seats	20
Rear Seats	23
Heated/Ventilated Seats	24
Heated Steering Wheel	25
Tilt/Telescoping Steering Column	26

OPERATING YOUR VEHICLE

Engine Break-In Recommendations	27
Headlight Switch	28
Turn Signal/Wiper/Washer/High Beam Lever	29
Auto Dimming Mirrors	30
Speed Control	30
Electronic Range Selection (ERS)	34
Manual Climate Controls	35
Automatic Temperature Controls (ATC)	36
ParkSense® Rear Park Assist	37
ParkView® Rear Back-Up Camera	37
Blind Spot Monitoring	38
Liftgate Flipper Glass	38
Power Sunroof	39
Wind Buffeting	41

ELECTRONICS

Your Vehicle's Sound System	42
Media Center 130 (Sales Code RES)	44
Media Center 130 With Satellite Radio (Sales Code RES + RSC)	46
Media Center 430/430N (Sales Code RBZ/RHB)	48
Media Center 730N (Sales Code RHR)	57
Sirius XM™ Satellite Radio/Travel Link	67
Steering Wheel Audio Controls	70

iPod®/USB/MP3 Control	71
Uconnect™ Phone	72
Uconnect™ Voice Command	75
Bluetooth® Streaming Audio	77
Video Entertainment System (VES)™	77
Electronic Vehicle Information Center (EVIC)	79
Programmable Features	80
Universal Garage Door Opener (HomeLink®)	80
Power Inverter	83
Power Outlets	83

OFF-ROAD CAPABILITIES

Quadra-Trac I® Four-Wheel Drive	85
Quadra-Trac II®/Quadra-Drive II® Four-Wheel Drive	85
Hill Start Assist/Hill Descent Control	89

UTILITY

Trailer Towing Weights (Maximum Trailer Weight Ratings)	90
Tow/Haul Mode	91
Recreational Towing (Behind Motorhome, Etc.)	91

SRT8

AutoStick®	94
Selec-Track™	95
Performance Features	96
Summer/Three-Season Tires	97

WHAT TO DO IN EMERGENCIES

24-Hour Towing Assistance	98
Instrument Cluster Warning Lights	98
If Your Engine Overheats	102
Jacking And Tire Changing	103
Battery Location	109
Jump-Starting	109
Emergency Tow Hooks	112
Shift Lever Override	112
Towing A Disabled Vehicle	113
Event Data Recorder (EDR)	114

MAINTAINING YOUR VEHICLE

Opening The Hood	115
Fuel Door Release	115
Engine Compartment Fluids And Capacities	117
Maintenance Chart	122
Fuses	127
Tire Pressures	130
Wheel And Wheel Trim Care	131
Exterior Bulbs	132

TABLE OF CONTENTS

CONSUMER ASSISTANCE

Chrysler Group LLC Customer Center	133
Chrysler Canada Inc. Customer Center	133
Assistance For The Hearing Impaired	133
Publications Ordering	133
Reporting Safety Defects In The 50 United States And Washington, D.C.	134

MOPAR ACCESSORIES

Authentic Accessories By MOPAR®	135
---	-----

INDEX	136
------------------------	-----

FAQ (How To?)

Frequently Asked Questions	139
--------------------------------------	-----

INTRODUCTION/WELCOME

WELCOME FROM CHRYSLER GROUP LLC

Congratulations on selecting your new Chrysler Group LLC vehicle. Be assured that it represents precision workmanship, distinctive styling, and high quality - all essentials that are traditional to our vehicles.

Your new Chrysler Group LLC vehicle has characteristics to enhance the driver's control under some driving conditions. These are to assist the driver and are never a substitute for attentive driving. They can never take the driver's place. Always drive carefully.

Your new vehicle has many features for the comfort and convenience of you and your passengers. Some of these should not be used when driving because they take your eyes from the road or your attention from driving. Never text while driving or take your eyes more than momentarily off the road.

This guide illustrates and describes the operation of features and equipment that are either standard or optional on this vehicle. This guide may also include a description of features and equipment that are no longer available or were not ordered on this vehicle. Please disregard any features and equipment described in this guide that are not available on this vehicle. Chrysler Group LLC reserves the right to make changes in design and specifications and/or make additions to or improvements to its products without imposing any obligation upon itself to install them on products previously manufactured.

This User Guide has been prepared to help you quickly become acquainted with the important features of your vehicle. It contains most things you will need to operate and maintain the vehicle, including emergency information.

The DVD includes a computer application containing detailed owner's information which can be viewed on a personal computer or MAC computer. The multimedia DVD also includes videos which can be played on any standard DVD player (including the Media Center Touch-Screen Radios). Additional DVD operational information is located on the back of the DVD sleeve.

For complete owner information, refer to your Owner's Manual on the DVD in the owner's kit provided at the time of new vehicle purchase. For your convenience, the information contained on the DVD may also be printed and saved for future reference.

Chrysler Group LLC is committed to protecting our environment and natural resources. By converting from paper to electronic delivery for the majority of the user information for your vehicle, together we greatly reduce the demand for tree-based products and lessen the stress on our environment.

Vehicles Sold In Canada

With respect to any vehicles sold in Canada, the name Chrysler Group LLC shall be deemed to be deleted and the name Chrysler Canada Inc. used in substitution therefore.

INTRODUCTION/WELCOME

Rollover Warning



WARNING!

- Pedals that cannot move freely can cause loss of vehicle control and increase the risk of serious personal injury.
- Always make sure that objects cannot fall into the driver foot well while the vehicle is moving. Objects can become trapped under the brake pedal and accelerator pedal causing a loss of vehicle control.
- Failure to properly follow floor mat installation or mounting can cause interference with the brake pedal and accelerator pedal operation causing loss of control of the vehicle.
- Never use the 'PARK' position as a substitute for the parking brake. Always apply the parking brake fully when parked to guard against vehicle movement and possible injury or damage.
- Refer to your Owner's Manual on the DVD for further details.

INTRODUCTION/WELCOME

USE OF AFTERMARKET PRODUCTS (ELECTRONICS)

The use of aftermarket devices including cell phones, MP3 players, GPS systems, or chargers may affect the performance of on-board wireless features including Keyless Enter-N-Go™ and Remote Start range. If you are experiencing difficulties with any of your wireless features, try disconnecting your aftermarket devices to see if the situation improves. If your symptoms persist, please see an authorized dealer.

CHRYSLER, DODGE, JEEP, RAM TRUCK, ATF+4, MOPAR and Uconnect are registered trademarks of Chrysler Group LLC.

COPYRIGHT ©2012 CHRYSLER GROUP LLC



CONTROLS AT A GLANCE

DRIVER COCKPIT



CONTROLS AT A GLANCE













- A. Headlight Switch pg. 28
- B. Electronic Vehicle Information Center (EVIC) Controls pg. 79
- C. Turn Signal/Wiper/Washer/High Beams Lever (behind steering wheel) pg. 29
- D. Instrument Cluster pg. 8
- E. Electronic Vehicle Information Center (EVIC) Display pg. 79
- F. Ignition Switch (behind steering wheel)
- G. Audio System (touch-screen-radio shown) pg. 42
- H. Climate Controls pg. 35
- I. Transmission Gear Selector
- J. SWITCH PANEL
 - Electronic Stability Control pg. 100
 - Tow/Haul pg. 91
 - Heated Steering Wheel pg. 25
 - Hazard Switch
 - Power Inverter pg. 83
 - ParkSense® pg. 37
- K. Speed Control pg. 30
- L. Fuel Door Release pg. 115
- M. Hood Release pg. 115
- N. Parking Brake Release
- O. Power Mirrors
- P. Power Windows
- Q. Power Door Locks

CONTROLS AT A GLANCE



INSTRUMENT CLUSTER

Warning Lights



















-  - Low Fuel Warning Light
-  - Charging System Light**
-  - Oil Pressure Warning Light**
-  - Engine Temperature Warning Light
-  - Transmission Temperature Warning Light
-  - Anti-Lock Brake (ABS) Light**
-  - Air Bag Warning Light**
-  - Electronic Throttle Control (ETC) Light
-  - Tire Pressure Monitoring System (TPMS) Light
-  - Seat Belt Reminder Light
- BRAKE**
-  - Malfunction Indicator Light (MIL)**
-  - Electronic Stability Control (ESC) Activation/Malfunction Indicator Light*
-  - SERV (Service) 4WD Indicator Light

(See page 98 for more information.)

CONTROLS AT A GLANCE



Indicators

- | | | | |
|---|---|---|---|
|  | - Turn Signal Indicators |  | - Adaptive Cruise Control (ACC) SET Indicator* |
|  | - High Beam Indicator |  | - Hill Descent Control Indicator* |
|  | - Front Fog Light Indicator* |  | - Park/Headlight ON Indicator* |
|  | - Vehicle Security Indicator* |  | - Electronic Stability Control (ESC) Off Indicator* |
|  | - TOW/HAUL Indicator* |  | - Windshield Washer Fluid Low Indicator |
|  | - 4WD LOW Indicator |  | - Door Ajar Indicator |
|  | - Loose Gas Cap Indicator |  | - Forward Collision Warning (FCW) OFF Indicator* |
|  | - Electronic Speed Control ON Indicator |  | - Air Suspension Down Indicator* |
|  | - Electronic Speed Control SET Indicator |  | - Air Suspension Up Indicator* |
|  | - Adaptive Cruise Control (ACC) ON Indicator* |  | - Liftgate Ajar Indicator |

* If equipped

** Bulb Check with Key On

GETTING STARTED

KEY FOB

Locking And Unlocking The Doors/Liftgate

- Press the LOCK button once to lock all the doors and the liftgate. Press the UNLOCK button once to unlock the driver's door only and twice within five seconds to unlock all the doors and liftgate.



- All doors can be programmed to unlock on the first press of the UNLOCK button. Refer to Programmable Features in this guide.

Power Liftgate

- Press the LIFTGATE button twice within five seconds to power open/close the Power Liftgate. If the button is pressed while the liftgate is being power closed, the liftgate will reverse to the full open position.
- Also, the power liftgate may be closed by pressing the Liftgate switch located on the left rear trim panel, near the liftgate opening. Pressing once will close the liftgate only. This button cannot be used to open the liftgate.

Panic Alarm

- Press the PANIC button once to turn the panic alarm on.
- Wait approximately three seconds and press the button a second time to turn the panic alarm off.

Emergency Key

- Should the battery in the vehicle or the Key Fob transmitter go dead, there is an emergency key located in the Key Fob that can be used for locking and unlocking the doors. To remove the emergency key, slide the button at the top of the Key Fob sideways with your thumb and then pull the key out with your other hand.
- The emergency key is used to unlock/lock the driver's door and the glove compartment.

GETTING STARTED

- In case the Key Fob battery is dead, use the emergency key to open the door. If the vehicle is equipped with Keyless Enter-N-Go™, remove the ENGINE START/STOP button by inserting the metal part of the emergency key under the chrome bezel at the 6 o'clock position and gently pry the button loose.



NOTE: The ENGINE START/STOP button should only be removed or inserted with the ignition in the LOCK position (OFF position for Keyless Enter-N-Go™).

- With the ENGINE START/STOP button removed, start the vehicle by inserting the Key Fob in the ignition and turning to the Start position.



CAUTION!

- If your vehicle battery becomes low or dead, your Key Fob will become locked in the ignition.
- Do not attempt to remove the Key Fob while in this condition, damage could occur to the Key Fob or ignition module. Only remove the emergency key for locking and unlocking the doors.
- Leave the Key Fob in the ignition and either:
 - Jump Start the vehicle.
 - Charge the battery.

GETTING STARTED

WARNING!

- Leaving unattended children in a vehicle is dangerous for a number of reasons. A child or others could be severely injured or killed. Children should be warned not to touch the parking brake, brake pedal, or the shift lever. Do not leave the Key Fob inside the vehicle or in the ignition. A child could start the vehicle, operate power windows, other controls, or move the vehicle.
- Do not leave children or animals inside parked vehicles in hot weather. Interior heat build-up may cause them to be severely injured or killed.
- Keep Key Fob transmitters away from children. Operation of the Remote Start System, windows, door locks or other controls could cause serious injury or death.
- Driving with the liftgate open can allow poisonous exhaust gases into your vehicle. You and your passengers could be injured by these fumes. Keep the flipper glass closed when you are operating the vehicle.

REMOTE START

- Press the REMOTE START button  on the Key Fob twice within five seconds. Pressing the REMOTE START button a third time shuts the engine off.
- To drive the vehicle, with a valid Keyless Enter-N-Go™ Key Fob within 5 ft (1.5m) of the driver's side of the vehicle, grab the front driver door handle to unlock the driver's door automatically, then press the Start/Stop switch. Or press the UNLOCK button, insert the Key Fob in the ignition and turn to the ON/RUN position.
- With remote start, the engine will only run for 15 minutes (timeout) unless the ignition is placed in the ON/RUN position.
- The vehicle must be started with the Key Fob after two consecutive timeouts.

WARNING!

- Do not start or run an engine in a closed garage or confined area. Exhaust gas contains Carbon Monoxide (CO) which is odorless and colorless. Carbon Monoxide is poisonous and can cause you or others to be severely injured or killed when inhaled.
- Keep Key Fob transmitters away from children. Operation of the Remote Start System, windows, door locks or other controls could cause you and others to be severely injured or killed.

GETTING STARTED

KEYLESS ENTER-N-GO™

- The Keyless Enter-N-Go™ system is an enhancement to the vehicle's Key Fob. This feature allows you to lock and unlock the vehicle's door(s) and liftgate without having to press the Key Fob lock or unlock buttons, as well as starting and stopping the vehicle with the press of a button.

To Unlock From The Driver or Passenger Side:

- With a valid Keyless Enter-N-Go™ Key Fob located outside the vehicle and within 5 ft (1.5m) of the driver or passenger side door handle, grab either front door handle to unlock the door automatically.



To Lock the Vehicle:

- Both front door handles have LOCK buttons located on the outside of the handle. With one of the vehicle's Keyless Enter-N-Go™ Key Fobs located outside the vehicle and within 5 ft (1.5m) of the driver's or passenger front door handle, press the door handle LOCK button to lock all four doors and liftgate.



NOTE:

- If "Unlock All Doors 1st Press" is programmed all doors will unlock when you grab hold of the front driver's door handle. To select between "Unlock Driver Door 1st Press" and "Unlock All Doors 1st Press", refer to the Electronic Vehicle Information Center (EVIC) in your vehicle's Owner's Manual on the DVD or Programmable Features in this guide for further information.
- If "Unlock All Doors 1st Press" is programmed all doors and liftgate will unlock when you press the liftgate button. If "Unlock Driver Door 1st Press" is programmed only the liftgate will unlock when you press the liftgate button. To select between "Unlock Driver Door 1st Press" and "Unlock All Doors 1st Press", refer to the Electronic Vehicle Information Center (EVIC) in your vehicle's Owner's Manual on the DVD or Programmable Features in this guide for further information.

GETTING STARTED

- If a Key Fob is detected in the vehicle when locking the vehicle using the power door lock switch, the doors and liftgate will unlock and the horn will chirp three times. On the third attempt, your Key Fob can be locked inside the vehicle.
- After pressing the Keyless Enter-N-Go™ LOCK button, you must wait 2 seconds before you can lock or unlock the vehicle using the door handle. This is done to allow you to check if the vehicle is locked by pulling on the door handle without the vehicle reacting and unlocking.
- If a Keyless Enter-N-Go™ door handle has not been used for 72 hours, the Keyless Enter-N-Go™ feature for that handle may time out. Pulling the deactivated front door handle will reactivate the door handle's Keyless Enter-N-Go™ feature.

Installing And Removing The ENGINE START/STOP Button

Installing The Button

- Remove the Key Fob from the ignition switch.
- Insert the ENGINE START/STOP button into the ignition switch with the lettering facing up and readable.
- Press firmly on the center of the button to secure it into position.

Removing The Button

- The ENGINE START/STOP button can be removed from the ignition switch for Key Fob use.
- Insert the metal part of the emergency key under the chrome bezel at the 6 o'clock position and gently pry the button loose.

NOTE:

- The ENGINE START/STOP button should only be removed or inserted with the ignition in the LOCK position (OFF position for Keyless Enter-N-Go™).



GETTING STARTED

Engine Starting/Stopping

Starting

- With a valid Keyless Enter-N-Go™ Key Fob inside the vehicle.
- Place the shift lever in PARK or NEUTRAL.
- While pressing the brake pedal, press the ENGINE START/STOP button once. If the engine fails to start, the starter will disengage automatically after 10 seconds.
- To stop the cranking of the engine prior to the engine starting, press the button again.



Stopping

- Place the shift lever in PARK.
- Press the ENGINE START/STOP button once. The ignition switch will return to the OFF position.
- **If the shift lever is not in PARK, the ENGINE START/STOP button must be held for two seconds and vehicle speed must be above 5 mph (8 km/h) before the engine will shut off.**

Accessory Positions with Engine Off

NOTE:

- The following functions are with the driver's foot OFF the Brake Pedal (Transmission in PARK or NEUTRAL Position).

Starting With The Ignition Switch In The OFF Position:

- Press the ENGINE START/STOP button once to change the ignition switch to the ACC position.
- Press the ENGINE START/STOP button a second time to change the ignition switch to the ON/RUN position.
- Press the ENGINE START/STOP button a third time to return the ignition switch to the OFF position.

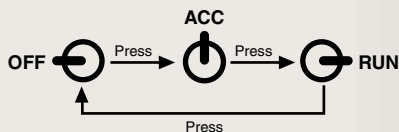

NOTE:

- If the ignition switch is left in the ACC or ON/RUN (engine not running) position and the transmission is in PARK, the system will automatically time out after 30 minutes of inactivity and the ignition will switch to the OFF position.

GETTING STARTED

THEFT ALARM

To Arm

- **Keyless Enter-N-Go™ button installed:** Press the Keyless Enter-N-Go™ Start/Stop button until the Electronic Vehicle Information Center (EVIC) indicates that the vehicle ignition is “OFF”. Press the power door lock switch while the door is open, press the Key Fob LOCK button, or with one of the Key Fobs located outside the vehicle and within 5 ft (1.5 m) of the driver’s and passenger front door handles, press the Keyless Enter-N-Go™ LOCK button located on the door handle.
- **Keyless Enter-N-Go™ button not installed:** Turn the ignition switch to the “OFF” position. Press the power door lock switch while the door is open, press the Key Fob LOCK button, or with one of the Key Fobs located outside the vehicle and within 5 ft (1.5 m) of the driver’s and passenger front door handles, press the Keyless Enter-N-Go™ LOCK button located on the door handle.

NOTE: After pressing the Keyless Enter-N-Go™ LOCK button, you must wait two seconds before you can lock or unlock the vehicle via the door handle.

To Disarm

- **Keyless Enter-N-Go™ button installed:** Press the Key Fob UNLOCK button or with one of the Key Fobs located outside the vehicle and within 5 ft (1.5 m) of the driver’s and passenger front door handles, grab the Keyless Enter-N-Go™ door handle and enter the vehicle, then press the Keyless Enter-N-Go™ Start/Stop button (requires at least one valid Key Fob in the vehicle).
- **Keyless Enter-N-Go™ button not installed:** Press the Key Fob UNLOCK button or with one of the Key Fobs located outside the vehicle and within 5 ft (1.5 m) of the driver’s and passenger front door handles, grab the Keyless Enter-N-Go™ door handle and enter the vehicle, then turn the ignition to the ON/RUN position.

SEAT BELT

- Be sure everyone in your vehicle is in a seat and using a seat belt properly.
- Position the lap belt across your thighs, below your abdomen. To remove slack in the lap portion, pull up a bit on the shoulder belt. To loosen the lap belt if it is too tight, tilt the latch plate and pull on the lap belt. A snug belt reduces the risk of sliding under the belt in a collision.
- Position the shoulder belt on your chest so that it is comfortable and not resting on your neck. The retractor will withdraw any slack in the belt.
- A shoulder belt placed behind you will not protect you from injury during a collision. You are more likely to hit your head in a collision if you do not wear your shoulder belt. The lap and shoulder belt are meant to be used together.

GETTING STARTED

- A belt that is too loose will not protect you properly. In a sudden stop you could move too far forward, increasing the possibility of injury. Wear your seat belt snugly.
- A frayed or torn belt could rip apart in a collision and leave you with no protection. Inspect the belt system periodically, checking for cuts, frays, or loose parts. Damaged parts must be replaced immediately. Do not disassemble or modify the system. Seat belt assemblies must be replaced after a collision if they have been damaged (bent retractor, torn webbing, etc.).
- The seat belts for both front seating positions are equipped with pretensioning devices that are designed to remove slack from the seat belt in the event of a collision.
- A deployed pretensioner or a deployed air bag must be replaced immediately.

WARNING!

In a collision, you and your passengers can suffer much greater injuries if you are not buckled up properly. You can strike the interior of your vehicle or other passengers, or you can be thrown out of the vehicle. Always be sure you and others in your vehicle are buckled up properly.

SUPPLEMENTAL RESTRAINT SYSTEM (SRS) — AIR BAGS

- This vehicle has Advanced Front Air Bags for both the driver and right front passenger as a supplement to the seat belt restraint system. The Advanced Front Air Bags will not deploy in every type of collision.
- Advanced Front Air Bags are designed to provide additional protection by supplementing the seat belts in certain frontal collisions depending on the severity and type of collision. Advanced Front Air Bags are not expected to reduce the risk of injury in rear, side, or rollover collisions.
- This vehicle is equipped with Supplemental Side Air Bag Inflatable Curtains to protect the driver, front and rear passengers sitting next to a window.
- This vehicle is equipped with Supplemental Seat-Mounted Side Air Bags to provide enhanced protection to help protect an occupant during a side impact.
- If the Air Bag Warning Light  is not on during starting, stays on, or turns on while driving, have the vehicle serviced by an authorized service center immediately.
- Refer to the Owner's Manual on the DVD for further details regarding the Supplemental Restraint System (SRS).

GETTING STARTED

WARNING!

- Relying on the air bags alone could lead to more severe injuries in a collision. The air bags work with your seat belt to restrain you properly. In some collisions, the air bags won't deploy at all. Always wear your seat belts even though you have air bags.
- Being too close to the steering wheel or instrument panel during Advanced Front Air Bag deployment could cause serious injury, including death. Air bags need room to inflate. Sit back, comfortably extending your arms to reach the steering wheel or instrument panel.
- Supplemental Side Air Bag Inflatable Curtains and Supplemental Seat-Mounted Side Air Bags need room to inflate. Do not lean against the door or window. Sit upright in the center of the seat.
- Being too close to the Supplemental Side Air Bag Inflatable Curtain and/or Seat-Mounted Side Air Bag during deployment could cause you to be severely injured or killed.
- Do not drive your vehicle after the air bags have deployed. If you are involved in another collision, the air bags will not be in place to protect you.
- After any collision, the vehicle should be taken to an authorized dealer immediately.

CHILD RESTRAINTS

- Children 12 years and under should ride properly buckled up in a rear seat, if available. According to crash statistics, children are safer when properly restrained in the rear seats rather than in the front.
- Every state in the United States and all Canadian provinces require that small children ride in proper restraint systems. This is the law, and you can be prosecuted for ignoring it.

Installing The LATCH - Compatible Child Restraint System

- Your vehicle's second row passenger seats are equipped with the child restraint anchorage system called LATCH, which stands for Lower Anchors and Tether for CHildren.
- All three rear seating positions have lower anchorages that are capable of accommodating LATCH-compatible child seats having flexible, webbing-mounted lower attachments.
- Child seats with fixed lower attachments must be installed in the outboard positions only.
- The vehicle's seat belt must be used for the center position.
- Never install LATCH-compatible child seats such that two seats share a common lower anchorage.

GETTING STARTED

- Loosen the child seat adjusters on the lower straps and tether straps so that you can attach the hook or connector to the lower tether anchorages more easily.



- Attach the lower hooks or connectors over the top of the anchorage bars, pushing aside the seat cover material. The rear seat lower anchorages are round bars, located at the rear of the seat cushion where it meets the seatback. The rear seat lower anchors can be readily identified by the symbol  located on the seatback directly above the anchorages and are just visible when you lean into the rear seat to install the child restraint.
- The tether strap should be attached to the tether anchor on the rear of the seatback (behind the gap panel) using the most direct path. **DO NOT USE** the cargo tie down loops located on the load floor.
- Tighten all three straps as you push the child restraint rearward and downward into the seat.



Installing The Child Restraint Using The Vehicle Seat Belts

- To install a child restraint, first pull enough of the seat belt webbing from the retractor to route it through the belt path of the child restraint and slide the seat belt latch plate into the buckle.
- Next, extract all the seat belt webbing out of the retractor and then allow the belt to retract into the retractor. Finally, pull on any excess webbing to tighten the lap portion around the child restraint. Any seat belt system will loosen with time, so check the belt occasionally, and pull it tight if necessary.

GETTING STARTED

- Once you have completed securing the child restraint with the seat belt, secure the top tether strap. The tether strap should be attached to the tether anchor on the rear of the seatback (behind the gap panel) using the most direct path. **DO NOT USE** the cargo tie down loops located on the load floor.

WARNING!

- In a collision, an unrestrained child, even a tiny baby, can become a projectile inside the vehicle. The force required to hold even an infant on your lap could become so great that you could not hold the child, no matter how strong you are. The child and others could be severely injured or killed. Any child riding in your vehicle should be in a proper restraint for the child's size.
- Improper installation of a child restraint to the LATCH anchorages can lead to failure of an infant or child restraint. The child could be severely injured or killed. Follow the manufacturer's directions exactly when installing an infant or child restraint.
- An incorrectly anchored tether strap could lead to increased head motion and possible injury to the child. Use only the anchor positions directly behind the child seat to secure a child restraint top tether strap.
- Rearward-facing child seats must never be used in the front seat of a vehicle with a front passenger air bag. An air bag deployment could cause infants in this position to be severely injured or killed.

FRONT SEATS

Power Seats

- The recline switch, located on the outboard side of the seat, controls seatback adjustment.
- The power seat switch controls forward/back, up/down and tilt adjustment.

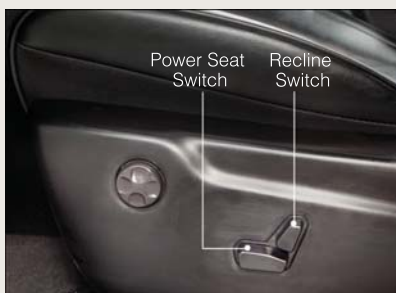

GETTING STARTED

Power Lumbar

- Push the switch forward to increase the lumbar support. Push the switch rearward to decrease the lumbar support.
- Pushing upward or downward on the switch will raise and lower the position of the support.



Memory Seat

- The memory seat feature allows you to save two different driver seating positions (excluding lumbar position), driver's outside mirror, tilt/telescoping steering column position, and radio station preset settings. The memory seat buttons are located on the driver's door panel.
- Adjust all memory profile settings, press the SET button then press 1 or 2 within five seconds.



- To program a Key Fob to the memory position, place the ignition switch in the LOCK position and remove the Key Fob, press and release the LOCK button on the Key Fob to be programmed within 5 seconds of pressing button 1 or 2.
- Place the ignition switch in the ON/RUN position, select Remote Linked to Memory in the Electronic Vehicle Information Center (EVIC) and enter Yes.
- Press 1 or 2 to recall the saved positions, or press UNLOCK on the programmed Key Fob.
- Refer to the Owner's Manual on the DVD for further details.

GETTING STARTED

Manual Seat Adjustment

Forward/Rearward

- Lift up on the adjusting bar located at the front of the seat near the floor and release when seat is in desired position.



Recliner

- Lift the rear lever located on the outboard side of the seat, lean back and release when seat is in desired position.



Fold-Flat Front Passenger Seat

- The front passenger seat can be folded flat to allow for extended cargo space. Pull up on the recliner lever to fold down the seatback.



GETTING STARTED

CAUTION!

Do not place any article under a power seat or impede its ability to move as it may cause damage to the seat controls. Seat travel may become limited if movement is stopped by an obstruction in the seat's path.

WARNING!

- Adjusting a seat while the vehicle is moving is dangerous. The sudden movement of the seat could cause you to lose control. The seat belt might not be properly adjusted, and you could be severely injured or killed. Only adjust a seat while the vehicle is parked.
- Do not ride with the seatback reclined so that the seat belt is no longer resting against your chest. In a collision, you could slide under the seat belt and be severely injured or killed. Use the recliner only when the vehicle is parked.

REAR SEATS

60/40 Split Rear Seat

To Lower Rear Seatback

- With the front seats fully upright and positioned forward, pull upward on the release lever and fold the rear seatback down.

To Raise Rear Seatback

- Raise the rear seatback and lock it into place.



To Recline Rear Seatback

- To recline the seatback, lean forward before lifting the handle, then lean back to the desired position and release the handle. Lift the handle to return the seatback to an upright position.

GETTING STARTED

HEATED/VENTILATED SEATS

Front Heated Seats

- The controls for front heated seats are located near the bottom center of the instrument panel (below the Climate Controls).
- Press the switch once to select High-level heating. Press the switch a second time to select Low-level heating. Press the switch a third time to shut the heating elements Off.



- If the High-level setting is selected, the system will automatically switch to Low-level after approximately 55 minutes. The Low-level setting will turn Off automatically after approximately 45 minutes.

Front Ventilated Seats

- Located in the seat cushion and seatback are small fans that draw the air from the passenger compartment and blow air through fine perforations in the seat cover to help keep the driver and front passenger cooler in higher ambient temperatures.
- There are two ventilated seat switches that allow the driver and passenger to operate the seats independently. The ventilated seat switches are located on the switch bank in the center stack of the instrument panel, just below the climate controls. The ventilated seat switches are used to control the speed of the fans located in the seat. Press the switch once to choose HIGH, press it a second time to choose LOW. Pressing the switch a third time will turn the ventilated seat OFF. When HIGH speed is selected both lights on the switch will be illuminated. When LOW speed is selected one light will be illuminated.

Rear Heated Seats

- Second row heated seat switches are located on the rear of the center console.
- Press the switch once to select High-level heating. Press the switch a second time to select Low-level heating. Press the switch a third time to shut the heating elements Off.



GETTING STARTED

- If the High-level setting is selected, the system will automatically switch to Low-level after approximately 55 minutes. The Low-level setting will turn Off automatically after approximately 45 minutes.

WARNING!

- Persons who are unable to feel pain to the skin because of advanced age, chronic illness, diabetes, spinal cord injury, medication, alcohol use, exhaustion or other physical conditions must exercise care when using the seat heater. It may cause burns even at low temperatures, especially if used for long periods of time.
- Do not place anything on the seat that insulates against heat, such as a blanket or cushion. This may cause the seat heater to overheat. Sitting in a seat that has been overheated could cause serious burns due to the increased surface temperature of the seat.

HEATED STEERING WHEEL

- The steering wheel contains a heating element that heats the steering wheel to one temperature setting.
- The heated steering wheel switch is located on the center instrument panel below the climate controls.
- Press the switch once to turn the heating element On. Press the switch a second time to turn the heating element Off.
- Once the heated steering wheel has been turned on, it will operate for approximately 58 to 70 minutes before automatically shutting off. The heated steering wheel can shut off early or may not turn on when the steering wheel is already warm.



GETTING STARTED

TILT/TELESCOPING STEERING COLUMN

Manual - Tilt/Telescoping Steering Column

- The tilt/telescoping control handle is located below the steering wheel at the end of the steering column.
- Push the handle down to unlock the steering column.
- To tilt the steering column, move the steering wheel upward or downward as desired. To lengthen or shorten the steering column, pull the steering wheel outward or push it inward as desired.
- Pull up on the handle to lock the column firmly in place.



Power - Tilt/Telescoping Steering Column

- The power tilt/telescoping steering control is located below the turn signal/wiper/washer/high beam lever on the steering column.
- To tilt the steering column, move the power tilt/telescoping control up or down as desired. To lengthen or shorten the steering column, pull the control toward you or push the control away from you as desired.

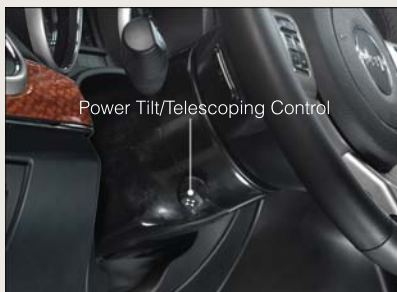

WARNING!

- Do not adjust the steering wheel while driving. The tilt/telescoping adjustment must be locked while driving. Adjusting the steering wheel while driving or driving without the tilt/telescoping adjustment locked could cause the driver to lose control of the vehicle. Failure to follow this warning may result in you and others being severely injured or killed.
- Moving the steering column while the vehicle is moving is dangerous. Without a stable steering column, you could lose control of the vehicle and have a collision. Adjust the column only while the vehicle is stopped.

OPERATING YOUR VEHICLE

ENGINE BREAK-IN RECOMMENDATIONS

- A long break-in period is not required for the engine and drivetrain (transmission and axle) in your vehicle.
- Drive moderately during the first 300 miles (500 km). After the initial 60 miles (100 km), speeds up to 50 or 55 mph (80 or 90 km/h) are desirable.
- While cruising, brief full-throttle acceleration within the limits of local traffic laws contributes to a good break-in. Wide-open throttle acceleration in low gear can be detrimental and should be avoided.
- The engine oil installed in the engine at the factory is a high-quality energy conserving type lubricant. Oil changes should be consistent with anticipated climate conditions under which vehicle operations will occur. For the recommended viscosity and quality grades, refer to “Maintaining Your Vehicle”.

NOTE: A new engine may consume some oil during its first few thousand miles (kilometers) of operation. This should be considered a normal part of the break-in and not interpreted as an indication of difficulty.

CAUTION!

Never use Non-Detergent Oil or Straight Mineral Oil in the engine or damage may result.

ENGINE BREAK-IN RECOMMENDATIONS — SRT8 VERSIONS

- A long break-in period is not required for the drivetrain (engine, transmission, and rear axle) in your new vehicle.
- Drive moderately during the first 500 mi (800 km). After the initial 60 mi (100 km), speeds up to 50 or 55 mph (80 or 90 km/h) are desirable.
- While cruising, brief full-throttle acceleration within the limits of local traffic laws contributes to a good break-in. However, wide-open throttle acceleration in low gear can be detrimental and should be avoided.
- The engine oil, transmission fluid, and axle lubricant installed at the factory is high-quality and energy-conserving. Oil, fluid, and lubricant changes should be consistent with anticipated climate and conditions under which vehicle operations will occur. For the recommended viscosity and quality grades, refer to “Maintaining Your Vehicle”.

NOTE: A new engine may consume some oil during its first few thousand miles (kilometers) of operation. This should be considered a normal part of the break-in and not interpreted as an indication of difficulty.



CAUTION!

Never use Non-Detergent Oil or Straight Mineral Oil in the engine or damage may result.

OPERATING YOUR VEHICLE

HEADLIGHT SWITCH

Automatic Headlights/Parking Lights/Headlights

- Rotate the headlight switch, located on the instrument panel to the left of the steering wheel, to the first detent for parking lights  and to the second detent for headlights .
 - With the parking lights or low beam headlights on, push the headlight switch once for fog lights.
 - Rotate the headlight switch to “A” for AUTO headlights.
- When set to “A” (AUTO), the system automatically turns the headlights on or off based on ambient light levels.

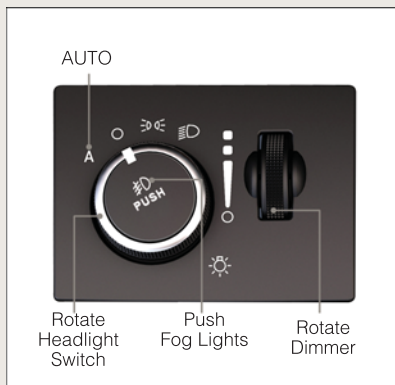

SmartBeams™

- This system automatically controls the use of the headlight high beams. Refer to Programmable Features in Electronics for further details.

Instrument Panel Dimmer

- Rotate the dimmer control to the extreme bottom position to fully dim the instrument panel lights and prevent the interior lights from illuminating when a door is opened.
- Rotate the dimmer control up to increase the brightness of the instrument panel when the parking lights or headlights are on.
- Rotate the dimmer control up to the next detent position to fully brighten the odometer and radio when the parking lights or headlights are on. Refer to your Media Center/Radio User Manual on the DVD for display dimming.
- Rotate the dimmer control up to the last detent position to turn on the interior lighting.

OPERATING YOUR VEHICLE

TURN SIGNAL/WIPER/WASHER/HIGH BEAM LEVER

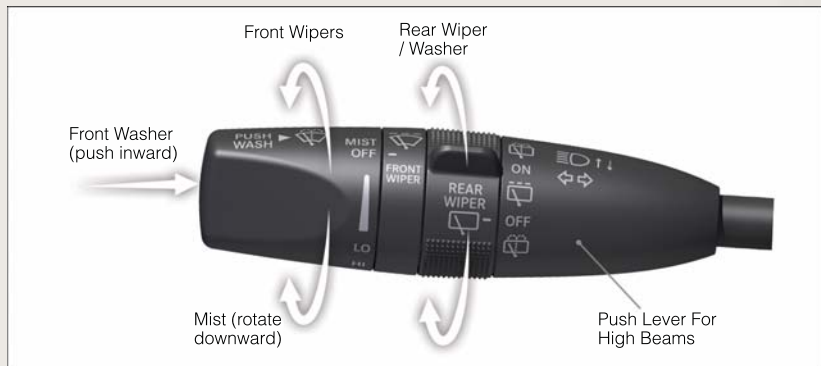

Turn Signal/Lane Change Assist

- Tap the lever up or down once and the turn signal (right or left) will flash three times and automatically turn off.

Front Wipers

Intermittent, Low And High Operation

- Rotate the end of the lever to the first detent position for one of four intermittent settings, the second detent for low wiper operation and the third detent for high wiper operation.

Washer Operation

- Push inward on the end of the lever and hold for as long as spray is desired.

Mist

- Rotate the end of the lever downward when a single wipe is desired.

NOTE: The mist feature does not activate the washer pump; therefore, no washer fluid will be sprayed on the windshield. The wash function must be activated in order to spray the windshield with washer fluid.

Rain Sensing Wipers

- This feature senses moisture on the vehicle's windshield and automatically activates the wipers for the driver when the switch is in the intermittent position. Rotate the end of the lever to one of four settings to activate this feature and adjust sensitivity.
- This feature can be activated/deactivated using the Electronic Vehicle Information Center (EVIC). Refer to the Programmable Features under the Electronics section in this guide.
- Refer to the Owner's Manual on the DVD for further details.

OPERATING YOUR VEHICLE

Rear Wiper

Wiper Operation

- Rotate the center portion of the lever forward to the first detent for intermittent operation and to the second detent for rear wiper operation.

Washer Operation

- Rotate the center portion of the lever past the second detent to activate the rear washer.

High Beam Operation

- Push the lever forward to activate the high beams. Pull the lever toward you for flash to pass.

NOTE: For safe driving, turn off high beams when oncoming traffic is present to prevent headlight glare and as a courtesy to other motorists.

AUTO DIMMING MIRRORS

- The rearview and driver side exterior mirror automatically adjusts for headlight glare from vehicles behind you.
- You can turn the feature on or off by pressing the button at the base of the rearview mirror. A light next to the button will illuminate to indicate when the dimming feature is activated.

SPEED CONTROL

- The speed control switches are located on the steering wheel.

Cruise ON/OFF

- Push the ON/OFF button to activate the Speed Control.
- CRUISE READY  will appear on the instrument cluster to indicate the Speed Control is on.
- Push the ON/OFF button a second time to turn the system off.



Set

- With the Speed Control on, push and release the SET - button to set a desired speed.

Accel/Decel

- Once a speed is set, pushing the RES + button once or the SET - button once will increase or decrease the set speed approximately 1 mph (2 km/h).

OPERATING YOUR VEHICLE

- Push and hold the RES + button to accelerate in 5mph (8 km/h) increments or push and hold the SET - button to decelerate in 5mph (8 km/h) increments; release the button to save the new set speed.

Resume

- To resume a previously selected set speed in memory, push the RES + button and release.

Cancel

- Push the CANCEL button, or apply the brakes to cancel the set speed and maintain the set speed memory.
- Push the ON/OFF button to turn the system off and erase the set speed memory.

Adaptive Cruise Control (ACC)

- If your vehicle is equipped with adaptive cruise control the controls operate exactly the same as the standard cruise control with one difference. You can set a specified distance you would like to maintain between you and the vehicle in front of you.
- If the ACC sensor detects a vehicle ahead, ACC will apply limited braking or acceleration automatically to maintain a preset following distance, while matching the speed of the vehicle ahead.
- If the sensor does not detect a vehicle directly ahead of you, it functions like a standard cruise control system, maintaining the speed you set.

Distance Setting (ACC Only)

- To set or change the distance setting, press the Distance button and release. Each time the button is pressed, the distance setting adjusts between long (3), medium (2), and short (1). The distance setting will default to the last set mode the next time the vehicle is restarted and the ACC system is turned on.
- The specified following distance for ACC can be set by varying the distance setting between 3 (long), 2 (medium), and 1 (short). Using this distance setting and the vehicle speed, ACC calculates and sets the distance to the vehicle ahead. This distance setting displays in the EVIC.

Mode (ACC Only)

- If desired, the Adaptive Cruise Control mode can be turned off and the system can be operated as a standard (fixed speed) Cruise Control. When in the standard (fixed speed) Cruise Control mode the distance setting feature will be disabled and the system will maintain the speed you set.
- To change between the different cruise modes, press the MODE button when the system is in either the OFF, READY or SET state. Pressing of the mode button in any state will result in changing to the new mode in the OFF state.
- Refer to your Owner's Manual on the DVD for further information.

OPERATING YOUR VEHICLE

Forward Collision Warning

- The Forward Collision Warning (FCW) system provides the driver with audible and visual warnings (within the EVIC) when it detects a potential frontal collision. The warnings are intended to provide the driver with enough time to react and avoid the potential collision.

Changing FCW Status

- The FCW feature has three settings and can be changed within the Electronic Vehicle Information Center (EVIC).
 - Far
 - Near
 - Off

NOTE: The FCW settings can only be changed when the vehicle is in PARK.

Far

- The default status of FCW is the “Far” setting.
- The far setting provides warnings for potential collisions more distant in front of the vehicle, allowing the driver to have the most reaction time to avoid a collision.
- This setting is designed to provide early warnings per NHTSA (National Highway Traffic Safety Administration) recommendations.
- More cautious drivers that do not mind frequent warnings may prefer this setting.

NOTE: This setting gives you the most reaction time.

Near

- Changing the FCW status to the “Near” setting, allows the system to warn you of a potential frontal collision when you are much closer.
- This setting provides less reaction time than the “Far” setting, which allows for a more dynamic driving experience.
- More dynamic or aggressive drivers that want to avoid frequent warnings may prefer this setting.

Off

- Changing the FCW status to “Off” prevents the system from warning you of a potential frontal collision.

NOTE:

- If FCW is set to “Off”, “FCW OFF” will be displayed in the EVIC.

Refer to the Owner’s Manual on the DVD for further details.

OPERATING YOUR VEHICLE

WARNING!

- Leaving the Electronic or Adaptive Speed Control system on when not in use is dangerous. You could accidentally set the system or cause it to go faster than you want. You could lose control and have a collision. Always leave the Electronic or Adaptive Speed Control system off when you are not using it.
- Electronic Speed Control can be dangerous where the system cannot maintain a constant speed. Your vehicle could go too fast for the conditions, and you could lose control. A collision could be the result. Do not use Electronic Speed Control in heavy traffic or on roads that are winding, icy, snow-covered or slippery.
- Adaptive Cruise Control (ACC) is a convenience system. It is not a substitute for active driving involvement. Pay attention to road, traffic, and weather conditions, vehicle speed, distance to the vehicle ahead; and, brake operation to ensure safe operation of the vehicle under all road conditions. Your attention is always required while driving to maintain safe control of your vehicle. Failure to follow these warnings can result in a collision or serious personal injury.

The ACC system:

- Does not react to pedestrians, oncoming vehicles, and stationary objects (i.e., a stopped vehicle in a traffic jam or a disabled vehicle).
- Cannot take street, traffic, and weather conditions into account, and may be limited upon adverse sight distance conditions.
- Does not predict the lane curvature or the movement of preceding vehicles and will not compensate for such changes.
- Does not always fully recognize complex driving conditions, which can result in wrong or missing distance warnings.
- May not detect a vehicle ahead when strong light (for example, sunrise or sunset) is directly shining on the front of the vehicle.
- Can only apply a maximum of 25% of the vehicle's braking capability, and will not bring the vehicle to a complete stop.

You should switch off the ACC system:

- When driving in fog, heavy rain, heavy snow, sleet, heavy traffic, and complex driving situations (i.e., in highway construction zones).
- When entering a turn lane or highway off ramp; when driving on roads that are winding, icy, snow-covered, slippery, or have steep uphill or downhill slopes; and when towing a trailer.
- When circumstances do not allow safe driving at a constant speed.
- Failure to follow these warnings can result in a collision.
- Forward Collision Warning (FCW) is not intended to avoid a collision on its own. The driver has the responsibility to avoid a collision by controlling the vehicle via braking and steering. Failure to follow this warning could lead to serious injury or death.

OPERATING YOUR VEHICLE

ELECTRONIC RANGE SELECTION (ERS)

- Electronic Range Select (ERS) allows you to limit the highest available transmission gear, and can be activated during any driving condition. When towing a trailer or operating the vehicle in off-road conditions, using ERS shift control will help you maximize both performance and engine braking.



- To switch from DRIVE mode to ERS mode, tap the shift lever to the left (-) once. The instrument cluster will display the current gear and the transmission will not upshift beyond that gear. Tapping the shift lever to the left (-) or right (+) will decrease or increase the top available gear. To disable ERS, simply hold the shift lever to the right (+) until "D" is again displayed in the instrument cluster.
- Switching between ERS and DRIVE mode can be done at any vehicle speed.
- Refer to your Owner's Manual on the DVD for further details.

OPERATING YOUR VEHICLE

MANUAL CLIMATE CONTROLS

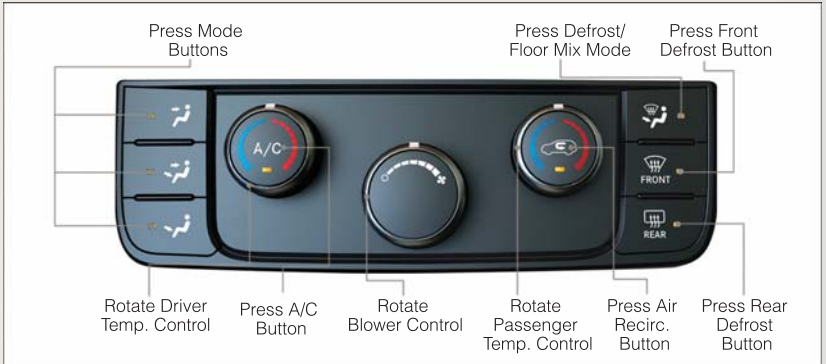

Air Recirculation

- Use recirculation for maximum A/C operation.
- For window defogging, turn the recirculation button off.
- Recirculation is not allowed in defrost mode.

Heated Mirrors

- The mirrors are heated to melt frost or ice. This feature is activated whenever you turn on the rear window defroster.

OPERATING YOUR VEHICLE

AUTOMATIC TEMPERATURE CONTROLS (ATC)

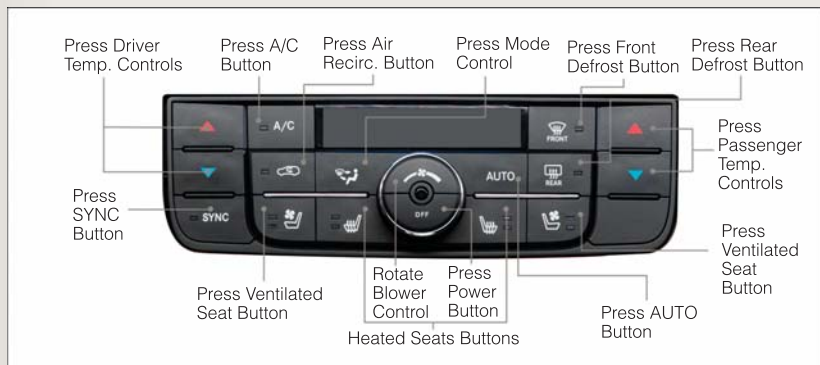

Automatic Operation

- Press the AUTO button.
- Select the desired temperature by pressing the Temperature Control buttons.
- The system will maintain the set temperature automatically.

Air Conditioning A/C

- If the air conditioning button is pressed while in the AUTO mode, the indicator light may flash three times to indicate the cabin air is being controlled automatically.

SYNC Temperature Button

- Press the SYNC button once to control driver and passenger temperatures simultaneously. Press the SYNC button a second time to control the temperatures individually.

Air Recirculation

- Use recirculation for maximum A/C operation.
- For window defogging, press air recirculation button off.
- If the recirculation button is pressed while in the AUTO mode, the indicator light may flash three times to indicate the cabin air is being controlled automatically.

Heated Mirrors

- The mirrors are heated to melt frost or ice. This feature is activated whenever you turn on the rear window defroster.

OPERATING YOUR VEHICLE

PARKSENSE® REAR PARK ASSIST

- The four ParkSense® sensors, located in the rear fascia/bumper, monitor the area behind the vehicle that is within the sensors' field of view.
- When an object is detected within two meters behind the rear bumper while the vehicle is in REVERSE, a warning will display in the Electronic Vehicle Information Center (EVIC) and a chime will sound (when Sound and Display is selected from the Customer Programmable Features section of the EVIC). As the vehicle moves closer to the object, the chime rate will change from slow, to fast, to continuous.

Cleaning the ParkSense® Sensors

- If "CLEAN PARK ASSIST SENSORS" appears in the Electronic Vehicle Information Center (EVIC), clean the ParkSense® sensors with water, car wash soap and a soft cloth. Do not use rough or hard cloths. Do not scratch or poke the sensors. Otherwise, you could damage the sensors.

NOTE: When the Instrument Cluster reads either Clean Sensor or Blinded, please clean off the bumper sensors to see if the condition is corrected.

PARKVIEW® REAR BACK-UP CAMERA

- You can see an on-screen image of the rear of your vehicle whenever the shift lever is put into REVERSE. The ParkView® Rear Back-Up Camera image will be displayed on the radio display screen, located on the center stack of the instrument panel.
- If the radio display screen appears foggy, clean the camera lens located on the liftgate.

WARNING!

Drivers must be careful when backing up even when using the ParkView® Rear Back-Up Camera. Always check carefully behind your vehicle, and be sure to check for pedestrians, animals, other vehicles, obstructions, or blind spots before backing up. You must continue to pay attention while backing up. Failure to do so can result in serious injury or death.

OPERATING YOUR VEHICLE

BLIND SPOT MONITORING

- The Blind Spot Monitoring (BSM) system uses two radar-based sensors, located inside the rear bumper fascia, to detect Highway licensable vehicles (automobiles, trucks, motorcycles etc.) that enter the blind spot zones from the rear/front/side of the vehicle.
- The Blind Spot Monitoring (BSM) system warning light, located in the outside mirrors, will illuminate if a vehicle moves into a blind spot zone.
- The BSM system can also be configured to sound an audible (chime) alert and mute the radio to notify you of objects that have entered the detection zones.
- Refer to your owner's manual on the DVD for further details.

LIFTGATE FLIPPER GLASS

- The liftgate flipper glass is unlocked when the liftgate is unlocked. To open the flipper glass, push up on the window switch located on the liftgate. When flipper glass is unlatched it will not completely raise, lift up on flipper glass handle to open.



NOTE: If a malfunction to the liftgate latch should occur, an emergency liftgate latch release, located on the inside of the vehicle, can be used to open the liftgate. The emergency liftgate latch release can be accessed through a snap-in cover located on the liftgate trim panel.

WARNING!

- Driving with the liftgate or flipper glass open can allow poisonous exhaust gases into your vehicle. You and your passengers could be injured by these fumes. Keep the flipper glass closed when you are operating the vehicle.
- To avoid injury, stand back when opening. Glass may automatically rise.

OPERATING YOUR VEHICLE

POWER SUNROOF

Express Open: Press the switch rearward and release. The sunroof will fully open and stop automatically.

Express Close: Press the switch forward and release. The sunroof will close automatically from any position.

Express Venting: Press and release the "VENT" button, and the sunroof will open to the vent position.



The power sunroof switches are located on the overhead console.

Manual Open/Close

- Press and hold the switch rearward to open or forward to close the sunroof. Any release of the switch will stop the movement, and the sunroof will remain in a partially open or closed position until the switch is pressed again.

OPERATING YOUR VEHICLE

CommandView® Sunroof With Power Shade

Express Open Power Shade: Press the switch rearward once and release. The shade will open half way and stop automatically. Press the switch a second time and the shade will fully open and stop automatically.

Command View Sunroof Switches: The command view sunroof functions exactly the same as the power sunroof. (Refer to power sunroof)



Express Close Power Shade: Press the switch forward and release. The shade will close automatically from any position.

NOTE:

- When the shade is fully open and the sunroof is open or in the vent position, pressing the switch once will close the shade to the half open position.
- When the shade is half open and the sunroof is open or in the vent position, pressing the switch once will close the sunroof and the shade to the fully closed position.

Manual Open/Close

- Press and hold the switch rearward to open or forward to close the power shade. Any release of the switch will stop the movement, and the power shade will remain in a partially open or closed position until the switch is pressed again.

Pinch Protection Feature

- This feature will detect an obstruction in the opening of the sunroof during Express Close operation. If an obstruction in the path of the sunroof is detected, the sunroof will automatically retract. Remove the obstruction if this occurs. Next, press the switch forward and release to Express Close.

NOTE: If three consecutive sunroof close attempts result in Pinch Protect reversals, the fourth close attempt will be a Manual Close movement with Pinch Protect disabled.

OPERATING YOUR VEHICLE

WARNING!

- Never leave children in a vehicle with the key in the ignition switch. Occupants, particularly unattended children, can become entrapped by the power sunroof while operating the power sunroof switch. Such entrapment may result in serious injury or death.
- In a collision, there is a greater risk of being thrown from a vehicle with an open sunroof. You could also be severely injured or killed. Always fasten your seat belt properly and make sure all passengers are properly secured.
- Do not allow small children to operate the sunroof. Never allow your fingers, other body parts, or any object to project through the sunroof opening. Injury may result.

WIND BUFFETING

- Wind buffeting can be described as a helicopter-type percussion sound. If buffeting occurs with the rear windows open, adjust the front and rear windows together.
- If buffeting occurs with the sunroof open, adjust the sunroof opening, or adjust any window. This will minimize buffeting.

ELECTRONICS

YOUR VEHICLE'S SOUND SYSTEM



ELECTRONICS



USB Port on Radio - for copying files from a memory stick to your radio's hard drive.

Audio Jack - works with iPod® devices or other players with a headphones jack and a 3.5mm cable.

Your Radio Sales Code

- Volume Up
- Change Audio Source
- Volume Down

Steering Wheel Audio Controls (right rear surface of steering wheel)

USB Port (located inside center console) - when connected, allows you to control your iPod® or memory stick using the radio or steering wheel audio controls.

ELECTRONICS

Media Center 130 (Sales Code RES)

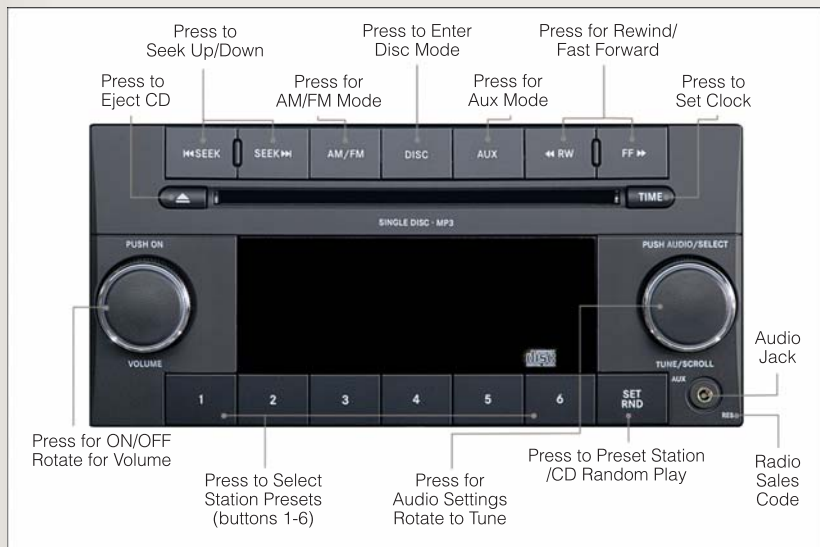

NOTE:

- Your radio has many features that add to the comfort and convenience of you and your passengers. Some of these radio features should not be used when driving because they take your eyes from the road or your attention from driving.

Clock Setting

- Press and hold the "TIME" button until the hours blink; turn the "TUNE/SCROLL" control knob to set the hours.
- Press the "TUNE/SCROLL" control knob until the minutes begin to blink; turn the "TUNE/SCROLL" control knob to set the minutes.
- Press the "TUNE/SCROLL" control knob to save the time change.
- To exit, press any button/knob or wait five seconds.

Equalizer, Balance And Fade

- Press the "TUNE/SCROLL" control knob and BASS, MID, TREBLE, BALANCE and FADE will display. Rotate the "TUNE/SCROLL" control knob to select the desired setting.

Radio Operation

Seek Up/Down Buttons

- Press to seek through radio stations in AM, FM, or SAT bands.
- Hold either button to bypass stations without stopping.

Store Radio Presets

- Press the “SET/RND” button once and SET 1 will show in the display. Then select button (1-6).
- A second station may be added to each push button. Press the “SET/RND” button twice and SET 2 will show in the display. Then select button (1-6).

CD/DISC Operation

Seek Up/Down Buttons

- Press to seek through CD tracks.
- Hold either button to bypass tracks without stopping.

SET/RND Button (Random Play)

- Press this button while the CD is playing to activate Random Play.
- This feature plays the selections on the CD in random order to provide an interesting change of pace.

Audio Jack Operation

- The Audio Jack allows a portable device, such as an MP3 player or a cassette player, to be plugged into the radio and utilize the vehicle’s audio system, using a 3.5 mm audio cable, to amplify the source and play through the vehicle speakers.
- Pressing the “AUX” button will change the mode to auxiliary device if the Audio Jack is connected, allowing the music from your portable device to play through the vehicle’s speakers.
- The functions of the portable device are controlled using the device buttons. The volume may be controlled using the radio or portable device.

ELECTRONICS

Media Center 130 with Satellite Radio (Sales Code RES + RSC)

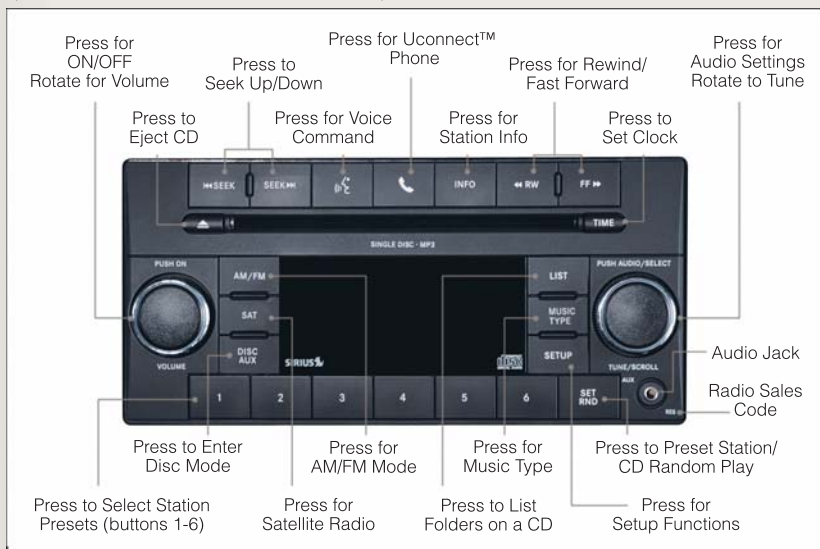

NOTE:

- Your radio may not be equipped with the Uconnect™ Voice Command and Uconnect™ Phone features. To determine if your radio has these features, press the Voice Command button on the radio. You will hear a voice prompt if you have the feature, or see a message on the radio stating “Uconnect Phone not available” if you do not.
- Your radio has many features that add to the comfort and convenience of you and your passengers. Some of these radio features should not be used when driving because they take your eyes from the road or your attention from driving.

Clock Setting

- Press and hold the “TIME” button until the hours blink; turn the “TUNE/SCROLL” control knob to set the hours.
- Press the “TUNE/SCROLL” control knob until the minutes begin to blink; turn the “TUNE/SCROLL” control knob to set the minutes.
- Press the “TUNE/SCROLL” control knob to save the time change.
- To exit, press any button/knob or wait five seconds.

Equalizer, Balance And Fade

- Press the “TUNE/SCROLL” control knob and BASS, MID, TREBLE, BALANCE and FADE will display. Rotate the “TUNE/SCROLL” control knob to select the desired setting.

Radio Operation

Seek Up/Down Buttons

- Press to seek through radio stations in AM, FM, or SAT bands.
- Hold either button to bypass stations without stopping.

Store Radio Presets

- Press the “SET/RND” button once and SET 1 will show in the display. Then select button (1-6).
- A second station may be added to each push button. Press the “SET/RND” button twice and SET 2 will show in the display. Then select button (1-6).

Music Type

- Press the “MUSIC TYPE” button to activate this mode. Press the “MUSIC TYPE” button again or turn the “TUNE/SCROLL” control knob to select the desired music type (Adult Hits, Country, Jazz, Oldies, Rock, etc.).
- Once a music type is chosen and the icon is displayed, press either “SEEK” button and the radio will only search for stations with the selected music type.

NOTE: The Music Type function only operates when in FM mode.

SETUP Button

- Pressing the “SETUP” button allows you to select between items that are available in that particular mode.
- Turn the “TUNE/SCROLL” control knob to scroll through the entries. Push the “AUDIO/SELECT” button to select an entry and make changes.

Sirius XM™ Satellite Radio

- Sirius XM™ Satellite Radio gives you over 130 channels, including 100% commercial-free music from nearly every genre, plus all your favorite sports, news, talk and entertainment channels—all with crystal clear, coast-to-coast coverage, all in one place and all at your fingertips.
- To access Sirius XM™ Satellite Radio, press the “SAT” hard-key.

CD/DISC Operation

Seek Up/Down Buttons

- Press to seek through CD tracks.
- Hold either button to bypass tracks without stopping.

SET/RND Button (Random Play)

- Press this button while the CD is playing to activate Random Play.
- This feature plays the selections on the CD in random order to provide an interesting change of pace.

ELECTRONICS

LIST Button

- Press the “LIST” button to bring up a list of all folders on the CD. Scroll up or down the list by turning the “TUNE/SCROLL” control knob.
- To select a folder from the list, press the “TUNE/SCROLL” control knob and the radio will begin playing the files contained in that folder.

Audio Jack Operation

- The Audio Jack allows a portable device, such as an MP3 player or a cassette player, to be plugged into the radio and utilize the vehicle’s audio system, using a 3.5 mm audio cable, to amplify the source and play through the vehicle speakers.
- Pressing the “AUX” button will change the mode to auxiliary device if the Audio Jack is connected, allowing the music from your portable device to play through the vehicle’s speakers.
- The functions of the portable device are controlled using the device buttons. The volume may be controlled using the radio or portable device.

Media Center 430/430N (Sales Code RBZ/RHB)

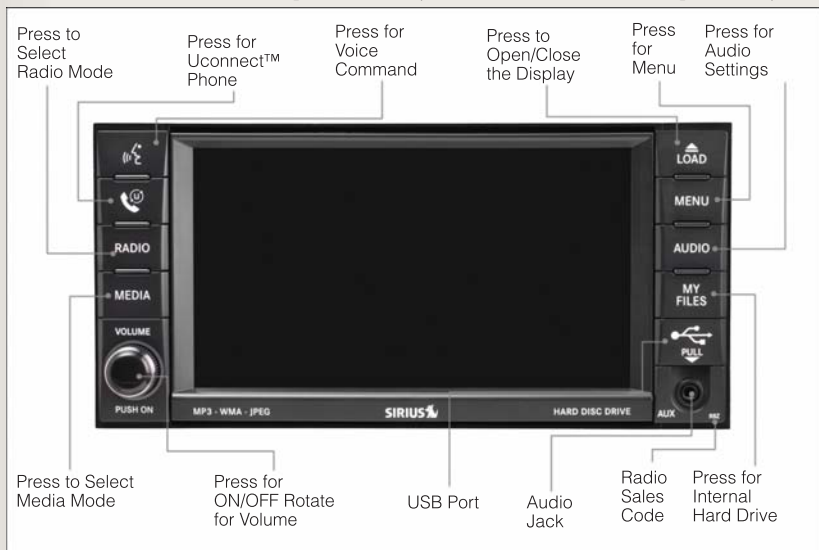

NOTE:

- Your radio may not be equipped with the Uconnect™ Voice Command and Uconnect™ Phone features. To determine if your radio has these features, press the Voice Command button on the radio. You will hear a voice prompt if you have the feature, or see a message on the radio stating “Uconnect Phone not available” if you do not.

ELECTRONICS

- Your radio has many features that add to the comfort and convenience of you and your passengers. Some of these radio features should not be used when driving because they take your eyes from the road or your attention from driving.

Clock Setting

- Turn the radio on, then touch the screen where the time is displayed.
- Touch the “USER CLOCK” soft-key (Navigation radio only).
- To adjust the hours, touch either the “HOUR FORWARD” or “HOUR BACKWARD” soft-key.
- To adjust the minutes, touch either the “MINUTE FORWARD” or “MINUTE BACKWARD” soft-key.
- To save the new time setting, touch the screen where the word “Save” is displayed.

Menu

- Press the “MENU” hard-key to access the System Setup menu and the My Files menu.
- Press the “MENU” hard-key in an active mode (SAT, CD, AUX, etc.) in order to change mode specific settings.

Equalizer, Balance And Fade

Audio Control Menu

- Press the “AUDIO” hard-key on the right side of the radio.
- Use either the arrow soft-keys or the cross-hair on the screen to change Balance and Fade. The “CENTER” soft-key resets the settings.



- Touch the “Equalizer” soft-key and use either the arrow soft-keys or the sliders on the screen to adjust BASS, MID, and/or TREBLE.

Display Settings

- Press the “MENU” hard-key and touch the “Display Settings” soft-key to access the Display Settings menu.
- Select the “Daytime Colors” soft-key to switch to manual daytime mode and to adjust the brightness of the display using daytime colors.

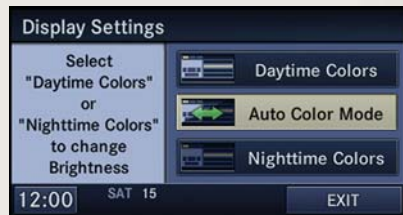

- Select the “Nighttime Colors” soft-key to switch to manual nighttime mode and to adjust the brightness of the display using nighttime colors.

ELECTRONICS

- Select the “Auto Color Mode” soft-key to switch to automatic daytime/nighttime mode and to control the brightness of the display using the dimmer switch of the vehicle.
- Touch the “EXIT” soft-key to save your settings.

Radio Operation

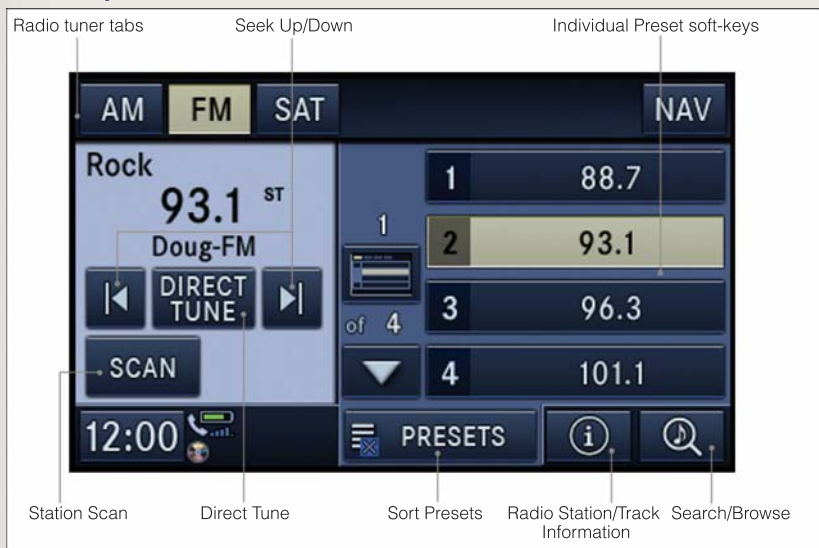

- To access Radio Mode, touch the “RADIO” hard-key on the left side of the faceplate, then touch the “AM,” “FM” or “SAT” soft-key at the top of the screen to select the band.

Seek Up/Seek Down

- Press the “Seek Up” or “Seek Down” soft-keys to seek through radio stations in AM, FM, or SAT bands. Hold either Seek to bypass stations without stopping.

Store Radio Presets

- Select the radio band by touching either the “AM,” “FM,” or “SAT” soft-key.
- Find the station to store by either pressing the “Seek Up” or “Seek Down” soft-keys, touching the “SCAN” soft-key, or by using the “DIRECT TUNE” soft-key.
- Once the station is found, touch and hold one of the “PRESET” soft-keys in the list to the right, until you hear a confirmation beep.

NOTE: If the Presets are not visible on the right side of the screen, press the “Presets” soft-key.

CD/DVD Disc Operation



- Press the “MEDIA” hard key to display the media source tabs at the top of the screen. Select the source by touching the “HDD,” “DISC,” or “AUX” media source soft-key tab.

NOTE: Your Touch-Screen Radio will usually automatically switch to the appropriate mode when something is first connected or inserted into the system.

Insert a CD/DVD Disc

- To insert a disc, press the “LOAD” hard-key.
- With the printed side upwards, insert the disc into the disc slot of the radio. The radio pulls the disc in automatically and closes the flip screen. The radio selects the appropriate mode after the disc is recognized, and starts playing the first track. The display shows “Reading...” during this process.

Seek Up/Seek Down

- Press the “Seek Up” or “Seek Down” soft-keys to seek through tracks in Disc Mode. Hold either Seek to bypass tracks without stopping.

Audio Jack Operation

- The Audio Jack allows a portable device, such as an MP3 player or a cassette player, to be plugged into the radio and utilize the vehicle’s audio system, using a 3.5 mm audio cable, to amplify the source and play through the vehicle speakers.

ELECTRONICS

- Pressing the “MEDIA” hard-key and then the “AUX” soft-key to change the mode to auxiliary device if the Audio Jack is connected, allowing the music from your portable device to play through the vehicle’s speakers.
- The functions of the portable device are controlled using the device buttons. The volume may be controlled using the radio or portable device.

Hard Disk Drive (HDD) Operation

- The Hard Disk Drive (HDD) mode gives you access to the audio files on the internal hard disk drive. It functions similar to a CD player, with the exception that the internal HDD can hold more tracks.
- It is also possible to import display pictures to the internal hard disk drive. The pictures can be displayed on the right half of the radio screen.
- Before using the HDD mode, you will need to copy songs and pictures to the internal hard drive. Songs and pictures can be added to the hard drive by using a CD or USB device (e.g. thumb drive or memory stick).

NOTE: WMA/MP3 Files and Selective Songs from a CD can also be added to the HDD. See the Media Center 430/430N User’s Manual for more information.

Copying Music From CD

- Press the “LOAD” hard-key.
- Insert a disc, then press the “MENU” hard-key.
- Touch the “MY FILES” soft-key, then select “MY MUSIC.”
- Touch the “Add Music Files to HDD” soft-key, then touch the “From Disc” soft-key in the next screen to start the process.



NOTE:

- You might need to select the folder or title depending on the CD, then press “DONE” to start the copy process.
- The copy progress is shown in the lower left corner of the screen.



Copying Music From USB

- The USB port on the radio face plate allows you to copy files to your hard drive. To access, lift up on the cover.
- Insert a USB device (e.g. thumb drive or memory stick), then select “MY MUSIC.”

ELECTRONICS

- Touch the “Add Music Files to HDD” soft-key, then touch the “From USB” soft-key in the next screen.
- Select the folders or titles you would like to copy, then touch the “DONE” soft-key to start the copy process.

NOTE: The copy progress is shown in the lower left corner of the screen.



Copying Pictures To The HDD

- Insert either a CD or a USB device containing your pictures in JPEG format.
- Press the “MY FILES” hard-key.
- Touch the “My Pictures” soft-key to get an overview of the currently stored images, then touch the “Add” soft-key.
- Touch the “From Disc” or “From USB” soft-key, then select the folders or pictures you wish to copy to the HDD. Use the “PAGE” soft-keys to page through the list of pictures.



- Touch the desired pictures or press the “All” soft-key for all pictures. Confirm your selections by touching the “SAVE” soft key.

NOTE: The copy progress is shown in the lower left corner of the screen.

Display a Picture on the Radio Screen

- Once the import is complete, the pictures will then be available in the “MY PICTURES” screen.
- Press the “MY FILES” hard-key, then touch the “My Pictures” soft-key. Touch the desired picture, then touch the “Set as Picture View” soft-key and then touch the “Exit” soft-key. Lastly press the “MENU” hard-key and then touch the “Picture View” soft-key to display the chosen picture on the radio screen.

NOTE:

- A check mark in the My Pictures screen indicates the currently used picture.
- You can also delete pictures by touching the “Delete” soft-key.

ELECTRONICS

Playing Music From The HDD

- Press the “MEDIA” hard key to display the media source tabs at the top of the screen. Touch the “HDD” soft-key tab. Touch the desired track soft-key to play or touch the “SEARCH/BROWSE” soft-key to search by artist, by album, by song, by genre, from a folder, or from Favorites.

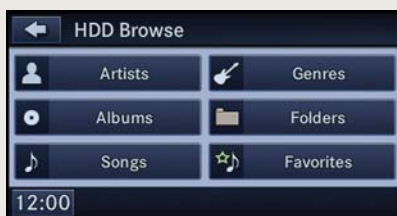

Cleaning Your Touch-Screen Radio

- Do not spray any liquid or caustic chemicals directly on the screen. Use a clean and dry micro fiber lens cleaning cloth in order to clean the touch-screen.
- If necessary, use a lint-free cloth dampened with a cleaning solution such as isopropyl alcohol or an isopropyl alcohol and water solution ratio of 50:50. Be sure to follow the solvent manufacturer's precautions and directions.

Garmin® Navigation

- Media Center 430N integrates Garmin's consumer-friendly navigation into your vehicle. Garmin Navigation includes a database with over 6 million points of interest.
- Touch the “NAV” soft-key in the upper right corner of the screen to access the Navigation system.

NOTE: For your own safety and the safety of others, it is not possible to use certain features while the vehicle is in motion.



ELECTRONICS

Main Navigation Menu

Finding Points Of Interest

- From the main Navigation menu, touch “Where To?,” then touch “Points of Interest.”
- Select a Category and then a subcategory, if necessary.
- Select your destination and touch “Go.”

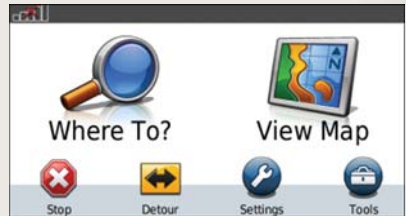

Finding A Place By Spelling The Name

- From the Main Navigation Menu, touch “Where to?,” then touch “Points of Interest” and then touch “Spell Name.”
- Enter the name of your destination.
- Touch “Done.”
- Select your destination and touch “Go.”

Entering A Destination Address

- From the main Navigation menu, touch “Where To?,” then touch “Address.”
- Follow the on-screen prompts to enter the address and touch “Go.”

Searching Near Another Location

- From the main Navigation menu, touch “Where To?,” then touch a destination and then touch “Near.”
- Select an option from the available choices.

Setting Your Home Location

- From the main Navigation menu, touch “Where To?,” then touch “Go Home.”
- You may enter your address directly, use your current location as your home address, or choose from recently found locations.

Edit Home Location

- From the main Navigation menu, touch “Where To?,” then touch “Favorites.”
- Next, touch the location you would like to edit, then touch “Press for More,” and then “Edit.”

Go Home

- A Home location must be saved in the system. From the Main Navigation menu, touch “Where To?,” then touch “Go Home.”

ELECTRONICS

Following Your Route

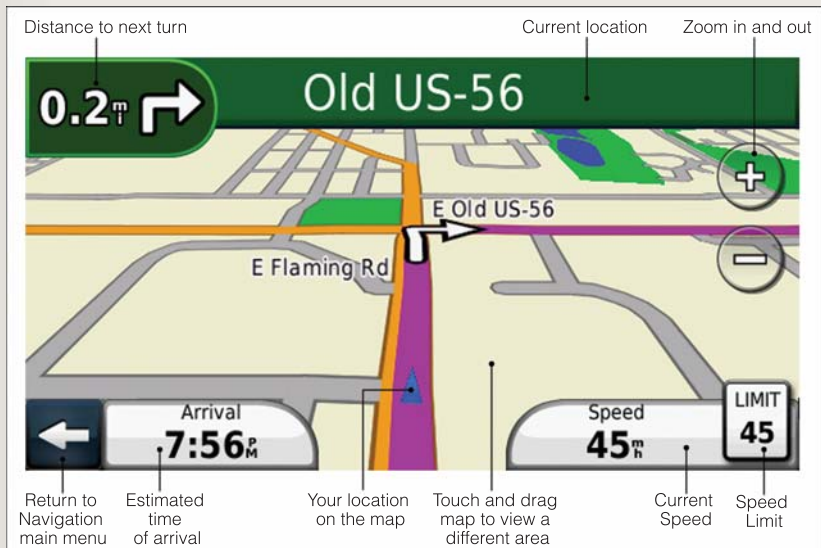

- Your route is marked with a magenta line on the map. If you depart from the original route, your route is recalculated. A speed limit icon could appear as you travel on major roadways.

Adding A Via Point

- To add a stop (Via Point) you must be navigating a route.
- Touch the “back arrow icon” to return to the Main Navigation menu.
- Touch “Where To?,” then search for the extra stop. Then select the stop to add from the search results.
- Touch “Go,” then touch “Add to Current Route.”

Taking A Detour

- To take a detour you must be navigating a route.
- Touch the “back arrow” icon to return to the Main Navigation menu.
- Touch “Detour.”

NOTE: If the route you are currently taking is the only reasonable option, the device might not calculate a detour.

ELECTRONICS

Acquiring Satellites

- The GPS Satellite strength bars indicate the strength of your satellite reception.
- Acquiring satellite signals can take a few minutes. When at least one of the bars is green, your device has acquired satellite signals.
- You may experience delays in acquisition of satellite signals when in areas with an obstructed view to the sky, such as garages, tunnels, or large cities with tall buildings.

Media Center 730N (Sales Code RHR)

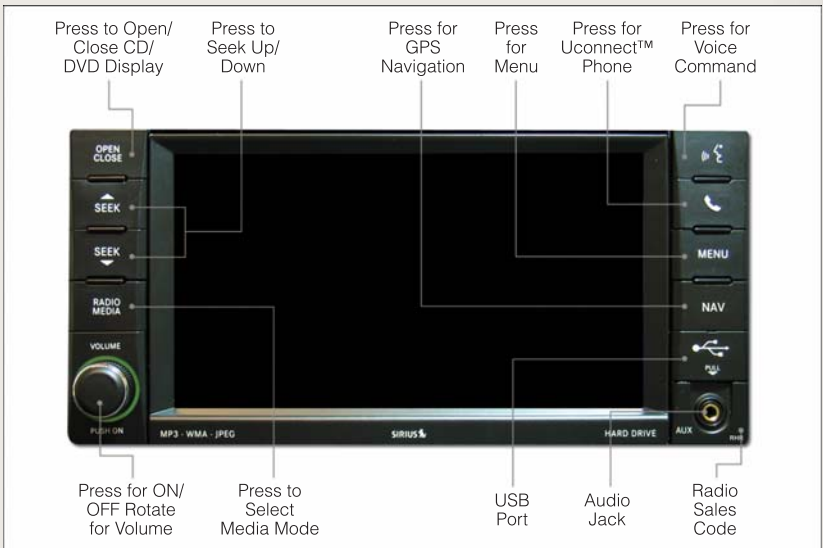

NOTE: Your radio may not be equipped with the Uconnect™ Voice Command and Uconnect™ Phone features. To determine if your radio has these features, press the Voice Command button on the radio. You will hear a voice prompt if you have the feature, or see a message on the radio stating “Uconnect Phone not available” if you do not.

- Your radio has many features that add to the comfort and convenience of you and your passengers. Some of these radio features should not be used when driving because they take your eyes from the road or your attention from driving.

ELECTRONICS

Clock Setting

- Turn the radio on, then touch the screen where the time is displayed.
- Touch the “USER CLOCK” soft-key.
- To adjust the hours, touch either the “HOUR FORWARD” or “HOUR BACKWARD” soft-key.
- To adjust the minutes, touch either the “MINUTE FORWARD” or “MINUTE BACKWARD” soft-key.
- To save the new time setting, touch the screen where the word “Save” is displayed.

Menu

- Press the “MENU” hard-key to access the System Setup menu and the My Files menu.
- Press the “MENU” hard-key in an active mode (SAT, CD, AUX, etc.) in order to change mode specific settings.

Equalizer, Balance And Fade

Audio Control Menu

- Press the “MENU” hard-key on the right side of the radio. Then press the “Audio Control” soft-key to get to the audio control menu.
- Use either the arrow soft-keys or the cross-hair on the screen to change Balance and Fade. The “CENTER” soft-key resets the settings.
- Touch the “Equalizer” soft-key and use either the arrow soft-keys or the sliders on the screen to adjust BASS, MID, and/or TREBLE.



Display Settings

- Press the “MENU” hard-key and touch the Display Settings soft-key to access the Display Settings menu.
- Select the “Daytime Colors” soft-key to switch to manual daytime mode and to adjust the brightness of the display using daytime colors.
- Select the “Nighttime Colors” soft-key to switch to manual nighttime mode and to adjust the brightness of the display using nighttime colors.
- Select the “Auto Color Mode” soft-key to switch to automatic daytime/nighttime mode and to control the brightness of the display using the dimmer switch of the vehicle.
- Touch the “EXIT” soft-key to save your settings.

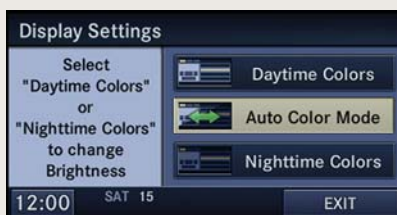

Radio Operation

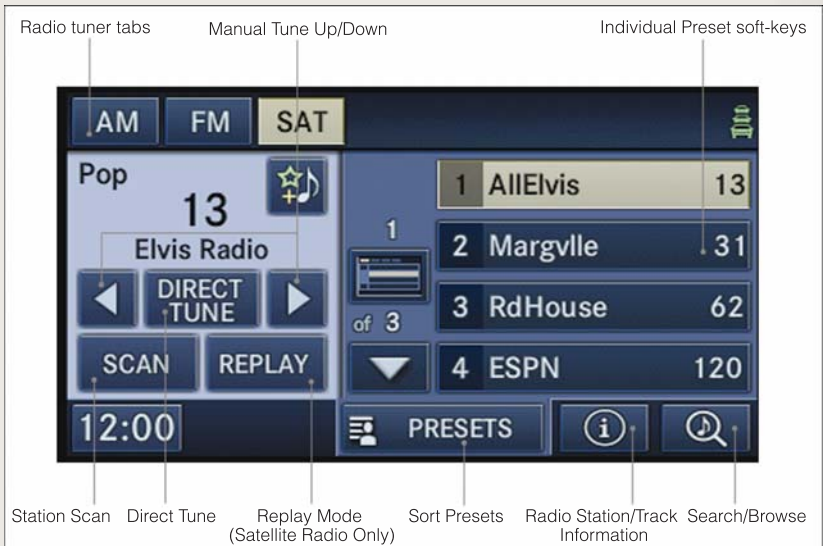

- To access Radio Mode, touch the “RADIO/MEDIA” hard-key on the left side of the faceplate repeatedly until AM/FM/SAT appears at the top of the screen, then touch the “AM,” “FM” or “SAT” soft-key to select the band.

Seek Up/Seek Down

- Press the “Seek Up” or “Seek Down” hard-keys to seek through radio stations in AM, FM, or SAT bands. Hold either Seek to bypass stations without stopping.

Store Radio Presets

- Select the radio band by touching either the “AM,” “FM,” or “SAT” soft-key.
- Find the station to store by either pressing the “Seek Up” or “Seek Down” hard-keys, touching the “SCAN” soft-key, or by using the “DIRECT TUNE” soft-key.
- Once the station is found, touch and hold one of the PRESET soft-keys in the list to the right, until you hear a confirmation beep.

NOTE: If the Presets are not visible on the right side of the screen, press the “Presets” soft-key.

ELECTRONICS

CD/DVD Disc Operation



- Press the “RADIO/MEDIA” hard key until the media source tabs are displayed at the top of the screen. Select the source by touching the “HDD,” “DISC,” or “AUX” media source soft-key tab.

NOTE: Your Touch-Screen Radio will usually automatically switch to the appropriate mode when something is first connected or inserted into the system.

Insert a CD/DVD Disc

- To insert a disc, press the “OPEN/CLOSE” hard-key.
- With the printed side upwards, insert the disc into the disc slot of the radio. The radio pulls the disc in automatically and closes the flip screen. The radio selects the appropriate mode after the disc is recognized, and starts playing the first track. The display shows “Reading...” during this process.

Seek Up/Seek Down

- Press the “Seek Up” or “Seek Down” hard-keys to seek through tracks in Disc Mode. Hold either Seek to bypass tracks without stopping.

Audio Jack Operation

- The Audio Jack allows a portable device, such as an MP3 player or a cassette player, to be plugged into the radio and utilize the vehicle’s audio system, using a 3.5 mm audio cable, to amplify the source and play through the vehicle speakers.

- Pressing the “RADIO/MEDIA” hard-key and then the “AUX” soft-key to change the mode to auxiliary device if the Audio Jack is connected, allowing the music from your portable device to play through the vehicle’s speakers.
- The functions of the portable device are controlled using the device buttons. The volume may be controlled using the radio or portable device.

Hard Disk Drive (HDD) Operation

- The Hard Disk Drive (HDD) mode gives you access to the audio files on the internal hard disk drive. It functions similar to a CD player, with the exception that the internal HDD can hold more tracks.
- It is also possible to import display pictures to the internal hard disk drive. The pictures can be displayed on the right half of the radio screen.
- Before using the HDD mode, you will need to copy songs and pictures to the internal hard drive. Songs and pictures can be added to the hard drive by using a CD or USB device (e.g. thumb drive or memory stick).

NOTE: WMA/MP3 Files and Selective Songs from a CD can also be added to the HDD. See the Media Center 730N User’s Manual for more information.

Copying Music From CD

- Press the “OPEN/CLOSE” hard-key.
- Insert a disc, then press the “MENU” hard-key.
- Touch the “MY FILES” soft-key, then select “MY MUSIC.”
- Touch the “Add Music Files to HDD” soft-key, then touch the “From Disc” soft-key in the next screen to start the process.



NOTE:

- You might need to select the folder or title depending on the CD, then press “Done” to start the copy process.
- The copy progress is shown in the lower left corner of the screen.



Copying Music From USB

- The USB port on the radio face plate allows you to copy files to your hard drive. To access, lift up on the cover.
- Insert a USB device (e.g. thumb drive or memory stick), then select “MY FILES”.

ELECTRONICS

- Touch the “MY MUSIC” soft-key, then touch the “Add Music Files” to HDD soft-key.
- Touch “From USB” soft-key, then select the folders or titles you would like to copy, and then touch the “SAVE” soft-key to start the copy process.

NOTE: The copy progress is shown in the lower left corner of the screen.



Copying Pictures To The HDD

- Insert either a CD or a USB device containing your pictures in JPEG format.
- Press the “MENU” hard-key to access the Settings Menu, then touch the “My Files” soft-key.
- Touch the “My Pictures” soft-key to get an overview of the currently stored images, then touch the “Add” soft-key.
- Touch the “From Disc” or “From USB” soft-key, then select the folders or pictures you wish to copy to the HDD. Use the “PAGE” soft-keys to page through the list of pictures.



- Touch the desired pictures or press the “All” soft-key for all pictures. Confirm your selections by touching the “SAVE” soft key.

NOTE: The copy progress is shown in the lower left corner of the screen.

Display a Picture on the Radio Screen

- Once the import is complete, the pictures will then be available in the “MY PICTURES” screen.

ELECTRONICS

- Press the “MENU” hard-key to access the Settings Menu, then touch the “My Files” soft-key and then touch the “My Pictures” soft-key. Touch the desired picture, then touch the “Set as Picture View” soft-key and then touch the “Exit” soft-key. Lastly press the “MENU” hard-key and then touch the “Picture View” soft-key to display the chosen picture on the radio screen.

NOTE:

- A check mark in the My Pictures screen indicates the currently used picture.
- You can also delete pictures by touching the “Delete” soft-key.

Playing Music From The HDD

- Press the “RADIO/MEDIA” hard key until the media source tabs are displayed at the top of the screen. Touch the “HDD” soft-key tab. Touch the desired track soft-key to play or touch the “SEARCH/BROWSE” soft-key to search by artist, by album, by song, by genre, from a folder, or from Favorites.

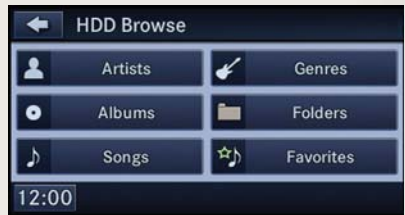

Cleaning Your Touch-Screen Radio

- Do not spray any liquid or caustic chemicals directly on the screen. Use a clean and dry micro fiber lens cleaning cloth in order to clean the touch-screen.
- If necessary, use a lint-free cloth dampened with a cleaning solution such as isopropyl alcohol or an isopropyl alcohol and water solution ratio of 50:50. Be sure to follow the solvent manufacturer's precautions and directions.

NAVIGATION

- Your navigation system receives GPS signals from up to 16 satellites to display the position of your vehicle. Map and database information is supplied through a hard disk drive.
- Touch the “NAV” hard-key on the radio face plate to access the Navigation system and the NAV - Main Menu.

ELECTRONICS

NOTE: For your own safety and the safety of others, it is not possible to use certain features while the vehicle is in motion.



Main Navigation Menu

Program a new destination	Route to a destination you programmed before	Search destination by Point of Interest	Enter or select a favorite Point of Interest	
Program or save trips with multiple destinations	Route to your Home destination	Search Points of Interest near the current vehicle position	View the map	Route to a nearby emergency facility

Finding Points Of Interest

- From the NAV main menu, touch the “Points of Interest” soft-key.
- Select a Category and then a subcategory, if necessary.
- Select your destination and touch “GO.”

Finding A Place By Entering The Street Address

- From the NAV main menu, touch “New Destination,” then touch “Street Address.”

NOTE: If the wrong State and/or Country displayed are incorrect, touch the corresponding soft-key to make the correction.

- Once the Country and State are set and the Street Address screen is displayed, begin spelling the street name in the speller. In the upper right corner the number of possible roads decreases.

ELECTRONICS

- Touch the “LIST” soft-key to display a list of possible street names. Select the correct street name.
- Next input the number.
- In the Confirm Route screen the navigation radio displays the complete address, a map of the destination area, and the current routing method for you to verify.
- Touch the “GO” soft-key to activate the route guidance.

Entering Your Home Location

- Press the “NAV” hard-key on the right side of the radio.
- From the Nav - Main Menu, touch “Guide Me Home” to enter your home address. If no home address has been set, touch “YES” to access the Enter Home Address menu.
- Touch “Street Address” to enter your address. Touch the soft-key with your state’s name and enter your street name into the speller.
- Once the street name has been input, touch “CONTINUE” to confirm. Enter the house number into the next screen. If more than one city has this address, you will then need to select your city from a list.
- Once the address is entered completely, the system shows a map of your home address area. Touch “SAVE” to confirm the address. The system will then ask if you want to go there, yes or no.

Change Home Address

- This procedure will allow you to change your Home Address if one has already been entered.
- Press the “MENU” hard-key, touch “My Files” and then touch “My Address Book.”
- Touch “Home,” then touch “Edit Contacts” and then “Change Address.”
- Touch the soft-key with your state’s name and enter your street name into the speller.
- Once the street name has been input, touch “CONTINUE” to confirm.
- Enter the house number into the next screen. If more than one city has this address, you will then need to select your city from a list.
- Touch the “SAVE” soft-key to confirm the address.

Go Home

- From the NAV main menu, touch “Guide Me Home” when you want to route to your home destination.

Where Am I Now?

- From the NAV main menu, touch “Where Am I Now?.” The Where Am I Now? menu displays location information for the current vehicle position.
- Touch the “NEARBY POI” soft-key to search for a local Point of Interest.
- Touch the “SAVE LOCATION” soft-key to save the current location in the Saved Locations memory.

ELECTRONICS

Route Guidance

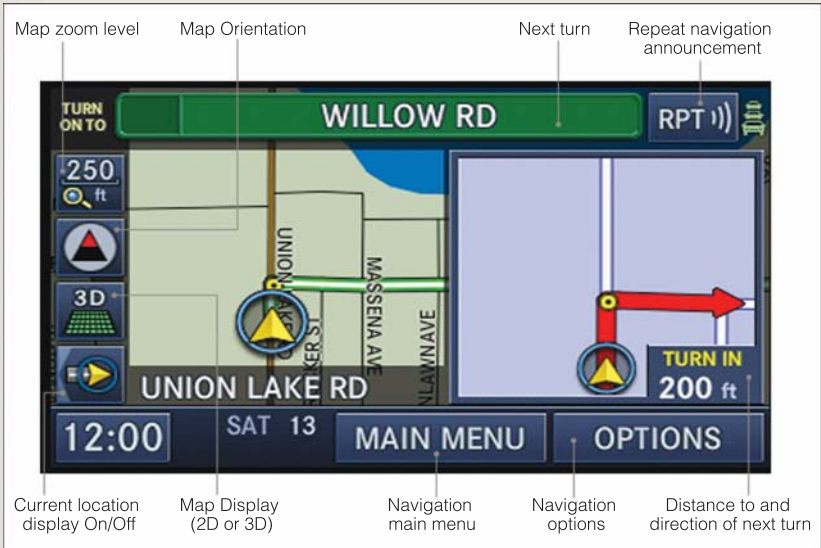

- After starting route guidance, the system calculates the route and announces: “Follow the arrows on the display.” You will receive navigation recommendations by voice messages and screen displays.

Route Options

- After pressing the “OPTIONS” soft-key in the Route Guidance Menu, the following information is displayed:
- In the left half of the screen, the current position and the current routing method are displayed.
- “Take Detour” will allow you to calculate a different route.
- “Find Nearby POI” to search for a local POI.
- “Destination Info” displays destination information.
- “View Turn List” lists streets utilized for the current route.
- “Save Destination” to save the destination address.
- “Change Method” will allow you to change the routing method.

Sirius XM™ SATELLITE RADIO/TRAVEL LINK

NOTE:

- Sirius Travel Link requires a subscription, sold separately after the 1 year trial subscription included with your vehicle purchase.
- Sirius Travel Link is only available in the United States.
 - The following describes features that are available when in Sirius XM™ Satellite Radio mode.
 - To access Sirius XM™ Satellite Radio, press the “RADIO/MEDIA” or “RADIO” and then touch the “SAT” soft-key tab.

Info

- Touch the “i” soft-key to view detailed information about the current Sirius XM™ Satellite channel.

Sirius XM™ Parental Controls

- Sirius XM™ offers the option to permanently block selected channels. Call 1-888-539-7474 and request the Family Package.
- Media Center 430/430N and 730N: Press the “MENU” hard-key while in Sirius XM™ Satellite Radio Mode, then touch the “Channel Lock” to enable and/or disable desired channels. The SEEK and SCAN function will then only display channels without Channel lock.

Search/Browse

- Touch the “magnifying glass” soft-key to search/browse the Sirius XM™ channel listing by Favorites and Categories such as Song, Artist and Channel Name. The Search/Browse also allows you manage your Favorites.

Sirius XM™ Satellite Radio Favorites (SAT Favorites)

- You can save 50 favorite songs and 50 favorite artists.
- Touch the “add favorite” soft-key to add either the song or the artist of the currently playing program to the SAT Favorites list.

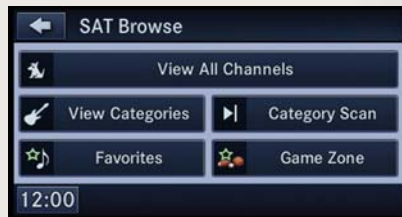

- You will see a favorite star indicator in the lower left side of the screen and a pop up will alert you that a favorite song or artist is currently playing on one of the Sirius XM™ satellite radio channels.

ELECTRONICS

NOTE: Refer to your Media Center 730N or Media Center 430/430N User's Manual for more information.



Display SAT Favorites List

- Touch the "Search/Browse" soft-key and select "Favorites" from the SAT Browse screen.
- Touch the desired favorites soft-key to switch the SAT tuner to the corresponding channel.

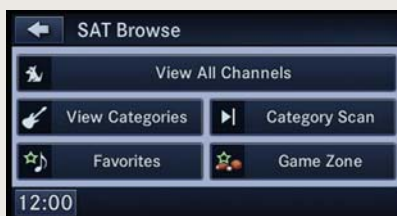

- You may use the "LIST" soft-key to toggle between:
 - Favorite Songs.
 - Favorite Artists.
 - Currently playing favorites.



Replay

- While you are in SAT mode, you can replay 44 minutes of the current Sirius XM™ channel (when the channel is changed, this audio buffer is erased). Press the REPLAY button to listen to the stored audio.



- You can touch the on-screen controls to pause and rewind audio playback, touch the SCAN button to preview each of the tracks stored in the buffer, or select a track from the list.
- The time displayed below the bar indicates how much time is present between the current buffer play position and the live broadcast.

ELECTRONICS

Replay Option	Option Description
Play/Pause	Touch to Pause content playback. Touch Pause/Play again to resume playback.
Rewind/RW	Rewinds the channel content in steps of 5 seconds. Touch and hold to rewind continuously, then release to begin playing content at that point.
Fast Forward/FW	Forwards the content, and works similarly to Rewind/RW. However, Fast Forward/FW can only be used when content has been previously rewound.
Replay Time	Displays the amount of time in the upper center of the screen by which your content lags the Live channel.
Live	Resumes playback of Live content at any time while replaying rewound content.

Sirius Travel Link (Media Center 730N (RHR) & Media Center 430N (RHB) Only)

NOTE:

- Sirius Travel Link requires a subscription, sold separately after the 1 year trial subscription included with your vehicle purchase.
- Sirius Travel Link is only available in the United States.
 - Sirius Travel Link brings a wealth of useful information into your vehicle and right to your fingertips.

ELECTRONICS

- To access Travel Link, press the MENU hard-key, then the Travel Link soft-key.



1 - Favorites	View and store your favorite location, theater and sport teams for quick access.
2 - Forecast	View detailed weather conditions, forecasts and ski/snowboarding conditions at local resorts.
3 - Ski Info	View ski and snowboarding conditions at local ski resorts.
4 - Fuel Prices	View detailed price information for fuel stations near your current location.
5 - Movies	View information on movies that are playing at theaters near your current location.
6 - Sports	View sports scores and upcoming events for all major sports.

STEERING WHEEL AUDIO CONTROLS

- The steering wheel audio controls are located on the rear surface of the steering wheel.

Right Switch

- Press the switch up or down to increase or decrease the volume.
- Press the button in the center to change modes AM/FM/CD/SAT.

Left Switch

- Press the switch up or down to search for the next listenable station or select the next or previous CD track.
- Press the button in the center to select the next preset station (radio) or to change CDs if equipped with a CD Changer.



ELECTRONICS

iPod®/USB/MP3 CONTROL

- There are many ways to play music from iPod®/MP3 players or USB devices through your vehicle's sound system.
- The remote USB port, located within the center console, allows you to plug an iPod® into the vehicle's sound system.

NOTE: If equipped with the Media Center 730N (RHR), the USB port on the faceplate allows the same functions as the remote USB port.

- Non-Touch-Screen Radios: To hear audio from devices connected to the USB port, press the "AUX" button on the radio faceplate
- Touch-Screen Radios: To hear audio from devices connected to the USB port, press the "MEDIA" hard-key, then touch the "AUX" or "iPod®" soft-key.



- When connected to this feature:
- The iPod® can be controlled using the radio buttons to Play, Browse, and List the iPod® or external devices contents.
- The iPod® battery charges when plugged into the USB port (if supported by the specific audio device).
- Compatible iPod® devices may also be controllable using voice commands. Refer to the Owner's Manual on the DVD for details.



NOTE:

- The USB port supports certain Mini, Classic, Nano, Touch, and iPhone® devices. The USB port also supports playing music from compatible external USB Mass Storage Class memory devices. For supported audio file formats, refer to the USB Port section in the Owner's Manual on the DVD. Refer to www.UconnectPhone.com website for a list of tested iPod®s. Some iPod® software versions may not fully support the USB port features. Please visit Apple's website for iPod® software updates.

WARNING!

Do not plug in or remove the iPod® or external device while driving. Failure to follow this warning could result in a collision.

ELECTRONICS

Uconnect™ Phone

- To determine if your vehicle is equipped with Uconnect™ Phone, press the “Uconnect™ Phone” button . If your vehicle has this feature, after a couple seconds you will hear a voice prompt. If not, you will see a message on the radio “Uconnect phone not available”.
- The Uconnect™ Phone is a voice-activated, hands-free, in-vehicle communications system with Voice Command Capability (see Voice Command section).

NOTE: To access the tutorial, press the “Uconnect™ Phone” button . After the BEEP, say “tutorial”. Press any hard-key/button or touch the display (Touch-Screen radio) to cancel the tutorial.

- The Uconnect™ Phone allows you to dial a phone number with your mobile phone using simple voice commands.
- Refer to your vehicle Owner’s Manual on the DVD for further details.

NOTE: The Uconnect™ Phone requires a mobile phone equipped with the Bluetooth® Hands-Free Profile, Version 1.0 or higher. For Uconnect™ customer support, call 1-877-855-8400 or visit www.UconnectPhone.com.

Phone Pairing

NOTE: Pairing is a one-time initial setup before using the phone.

- Press the “Phone” button  to begin.
- Wait for the “ready” prompt and BEEP.
- (After the BEEP), say “setup” or “Uconnect device setup”.
- (After the BEEP), say “device pairing”.
- (After the BEEP), say “pair a device”.
- Follow the audible prompts.



- You will be asked to say a four-digit Personal Identification Number (PIN), which you will later need to enter into your mobile phone. You can say any four-digit PIN. You will not need to remember this PIN after the initial pairing process.

ELECTRONICS

- You will then be prompted to give the phone pairing a name (each phone paired should have a unique name).
- Next you will be asked to give this new pairing a priority of 1 thru 7 (up to seven phones may be paired); 1 is the highest and 7 is the lowest priority. The system will only connect to the highest priority phone that exists within the proximity of the vehicle.
- You will then need to start the pairing procedure on your cell phone. Follow the Bluetooth® instructions in your cell phone Owner's Manual to complete the phone pairing setup.

Phonebook

Phonebook Download – Automatic Phonebook Transfer From Mobile Phone

- If equipped and specifically supported by your phone, Uconnect™ Phone automatically downloads names (text names) and number entries from your mobile phone's phonebook. Specific Bluetooth® Phones with Phone Book Access Profile may support this feature. Automatic Transfer is indicated by a green arrow at the bottom of the screen. See Uconnect™ website for supported phones.
- Automatic download and update, if supported, begins as soon as the Bluetooth® wireless phone connection is made to the Uconnect™ Phone, for example, after you start the vehicle.
- A maximum of 1000 entries per phone will be downloaded and updated every time a phone is connected to the Uconnect™ Phone.
- Depending on the maximum number of entries downloaded, there may be a short delay before the latest downloaded names can be used. Until then, if available, the previously downloaded phonebook is available for use.
- Only the phonebook of the currently connected mobile phone is accessible.
- Only the mobile phone's phonebook is downloaded. SIM card phonebook is not part of the Mobile phonebook.
- This downloaded phonebook cannot be edited or deleted on the Uconnect™ Phone. These can only be edited on the mobile phone. The changes are transferred and updated to Uconnect™ Phone on the next phone connection.



ELECTRONICS



Phonebook Edit

- Press the “Phone” button .
- (After the BEEP), say “phonebook”.
- (After the BEEP), say “new entry” or “list names” or “delete”.
- Follow the prompts.

Making A Phone Call

- Press the “Phone” button .
- (After the BEEP), say “dial” (or “call” a name).
- (After the BEEP), say number (or name).

Receiving A Call – Accept (And End)

- When an incoming call rings/is announced on Uconnect™, press the Phone button .
- To end a call, press the Phone button .

Mute (Or Unmute) Microphone During Call

- During a call, press the “Voice Command” button  VR .
- (After the BEEP), say “mute” (or “mute off”).

Transfer Ongoing Call Between Handset And Vehicle

- During a call, press the “Voice Command” button  VR .
- (After the BEEP), say “transfer call”.



Changing The Volume

- Start a dialogue by pressing the “Phone” button , then adjust the volume during a normal call.
- Use the radio ON/OFF VOLUME rotary knob to adjust the volume to a comfortable level while the Uconnect™ system is speaking. Please note the volume setting for Uconnect™ is different than the audio system.

WARNING!

- Any voice commanded system should be used only in safe driving conditions following local laws and phone use. All attention should be kept on the roadway ahead. Failure to do so may result in a collision causing you and others to be severely injured or killed.
- In an emergency, to use Uconnect™ Phone, your mobile phone must be:
 - turned on,
 - paired to Uconnect™ Phone,
 - and have network coverage.

Uconnect™ VOICE COMMAND

- The Uconnect™ Voice Command system allows you to control your AM, FM radio, satellite radio, disc player, HDD, Uconnect™ Phone, a memo recorder, and supported portable media devices.
- When you press the “Voice Command” button  VR located on the radio faceplate or steering wheel, you will hear a beep. The beep is your signal to give a command. If you do not say a command within a few seconds, the system will present you with a list of options. If you ever wish to interrupt the system while it lists options, press the “Voice Command” button  VR, listen for the BEEP, and say your command.

Voice Command Operation



- Start a dialogue by pressing the “Voice Command” button  VR, you will hear a beep. The beep is your signal to give a command. Below are a list of voice commands for each of the different modes.



Common Voice Commands (Examples)

Main Menu	“Radio” (to switch to the radio mode) “Disc” (to switch to the disc mode) “Memo” (to switch to the memo recorder) “System Setup” (to switch to system setup)
Radio Mode	“Frequency” (to change the frequency) “Next Station” (to select the next station) “Previous Station” (to select the previous station) “Radio Menu” (to switch to the radio menu) “Main Menu” (to switch to the main menu)
Sirius XM™ Satellite Radio Mode	“Channel Number” (to change the channel by its spoken number) “Next Channel” (to select the next channel) “Previous Channel” (to select the previous channel) “List Channel” (to hear a list of available channels) “Select Name” (to say the name of a channel) “Radio Menu” (to switch to the radio menu) “Main Menu” (to switch to the main menu)
Disc Mode	“Track” (#) (to change the track) “Next Track” (to play the next track) “Previous Track” (to play the previous track) “Main Menu” (to switch to the main menu)

ELECTRONICS

Memo Mode	<p>To switch to the voice recorder mode, say “Memo”. The following are common voice commands for this mode:</p> <p>“New Memo” (to record a new memo) — During the recording, you may press the Voice Command button  VR to stop recording. You proceed by saying one of the following commands:</p> <ul style="list-style-type: none">— “Save” (to save the memo)— “Continue” (to continue recording)— “Delete” (to delete the recording)— “Play Memos” (to play previously recorded memos) — During the playback you may press the Voice Command button  VR to stop playing memos. You proceed by saying one of the following commands: <ul style="list-style-type: none">— “Repeat” (to repeat a memo)— “Next” (to play the next memo)— “Previous” (to play the previous memo)— “Delete” (to delete a memo)— “Delete All” (to delete all memos)
-----------	--

SMS (Text Messaging)

- If equipped with Uconnect™ Voice Command, your Media Center 430N & 730N radios may be able to play incoming Short Message Service (SMS) messages (text messages) through the vehicle's sound system.
- It also allows you to respond by selecting from various pre-defined phrases.
- Not all phones are compatible with this feature. Refer to the phone compatibility list at www.UconnectPhone.com. Connected mobile phones must be bluetooth-compatible, and paired with your radio.
- Press the “Voice Command” button  VR and after the BEEP, say “SMS” to get started.

NOTE: To access the tutorial, press the “Voice Command” button  VR . After the BEEP, say “tutorial”. Press any hard-key/button or touch the display (Touch-Screen radio) to cancel the tutorial.

WARNING!

Any voice commanded system should be used only in safe driving conditions following local laws and phone use. All attention should be kept on the roadway ahead. Failure to do so may result in a collision causing you and others to be severely injured or killed.

Bluetooth® STREAMING AUDIO

- If equipped with Uconnect™ Voice Command, your Bluetooth-equipped iPod® devices, cell phones or other media players, may also be able to stream music to your vehicle's speakers. Your connected device must be Bluetooth-compatible, and paired with your Media Center radio (see Uconnect™ Phone for pairing instructions).



Non-Touch-Screen Radios: Press the "AUX" button on the radio faceplate until "BT" or "Audio Streaming" is displayed on the radio screen. Touch-Screen-Radios: Press the "RADIO/MEDIA" or "MEDIA" hard-key and then touch the "AUX" soft-key tab.

VIDEO ENTERTAINMENT SYSTEM (VES)™

System Operation

- The screen is located on the headliner behind the front seat. To lower the screen, press the release button located in the rear of the overhead console.
- The system may be controlled by the front seat occupants using the touch-screen radio, or by the rear seat occupants using the remote control.



- The video screen displays information in a split-screen format. The left side of the screen is referred to as Channel 1 and the right side of the screen is referred to as Channel 2. All modes except video modes are displayed in a split-screen format.
- To use the headphones, press the power button located on the right ear cup. Select the channel on the headphones (1 or 2) that corresponds to the channel selected on the VES™ screen.

ELECTRONICS

Operation Of The Touch-Screen Radio

- To view a DVD video, press the OPEN/CLOSE or LOAD hard-key and insert the disc. Playback will begin automatically after the DVD is recognized by the disc drive. If playback does not begin automatically, follow these steps:
- Press the MENU hard-key, then touch the Rear VES™ soft-key. If a chapter list appears on the right side of the screen touch the HIDE LIST soft-key to display the Rear VES™ Control screen.
- Touch the 1 soft-key to select an audio channel, then touch the DISC soft-key in the MEDIA column.

Operation Of The Remote

- The remote control operates similarly to any DVD remote you have used before and allows the rear seat passengers to change stations, tracks, discs and audio/video modes.
- The remote control is designed to control either channel by using the selector switch located on the right side of the remote.
- Pressing the power button will turn the VES™ system ON/OFF.
- Pressing the MODE button causes the Mode Selection menu to appear on the VES™ screen. Use the remote control arrow buttons to scroll through the available modes, then press ENTER to select the desired mode.

Auxiliary Audio/Video Input Jacks

- The Aux jacks are located on the rear of the center console.
- Connect the video game or other external media devices to the AUX jacks following the color coding for VES™ jacks.
- Using either the touch-screen radio or remote control, select AUX from the Rear VES™ Control or Mode Selection screen.
- Refer to your vehicle's Owners Manual on the DVD for further details.

ELECTRONICS

ELECTRONIC VEHICLE INFORMATION CENTER (EVIC)

- The EVIC features a driver interactive display that is located in the instrument cluster. Pressing the controls on the left side of the steering wheel allows the driver to select vehicle information and Personal Settings. For additional information, refer to Programmable Features in this guide.
- Press and release the UP Δ button to scroll upward through the main menus (Fuel Economy, Vehicle Info, Tire PSI, Cruise, Messages, Units, System Setup) and sub menus.
- Press and release the DOWN ∇ button to scroll downward through the main menus and sub menu.
- Press and release the SELECT \triangleright button for access to main menus, sub menu or to select a personal setting in the setup menu.
- Press the BACK button to scroll back to a previous menu or sub menu.



Compass Calibration

- This compass is self-calibrating, which eliminates the need to set the compass manually. When the vehicle is new, the compass may appear erratic and the EVIC will display “CAL” until the compass is calibrated.
- You may also calibrate the compass by completing one or more 360 degree turns (in an area free from large metal or metallic objects) until the “CAL” message displayed in the EVIC turns off. The compass will now function normally.

ECO

- The ECO message will appear in your EVIC display whenever you are driving in a fuel efficient manner.
- This feature allows you to monitor when you are driving in a fuel efficient manner, and it can be used to modify driving habits in order to increase fuel economy.

ELECTRONICS

PROGRAMMABLE FEATURES

Electronic Vehicle Information Center (EVIC)

- The EVIC can be used to program the following Personal Settings. Press the UP Δ or DOWN ∇ button until System Setup displays, then press the SELECT \triangleright button. Scroll through the settings using the UP or DOWN buttons. Press the SELECT \triangleright button to change the setting. Press the BACK button to scroll back to a previous menu or sub menu.
 - Select Language
 - Nav - Turn By Turn
 - Auto Unlock Doors
 - Remote Unlock Sequence
 - RKE Linked To Memory
 - Remote Start Comfort Sys.
 - Horn With Remote Lock
 - Horn With Remote Start
 - Flash Lamps With Lock
 - Headlamp Off Delay
 - Headlamps With Wipers
 - Easy Entry/Exit Seat
 - Tilt Mirror in Reverse
 - Key-Off Power Delay
 - Illuminated Approach
 - Display ECO Symbol
 - Keyless Enter-N-Go™
 - Auto High Beams
 - Wiper Mode
 - Hill Start Assist (HSA)
 - Blind Spot Alert
 - Forward Collision Warning
 - Park Assist System
 - Display Units of Measure In:
 - Liftgate Chime
 - Calibrate Compass
 - Compass Variance

UNIVERSAL GARAGE DOOR OPENER (HomeLink®)

- HomeLink® replaces up to three hand-held transmitters that operate devices such as garage door openers, motorized gates, lighting or home security systems. The HomeLink® unit is powered by your vehicle's 12 Volt battery.
- The HomeLink® buttons that are located in the overhead console or sunvisor designate the three different HomeLink® channels.
- The HomeLink® indicator is located above the center button.

Before You Begin Programming HomeLink®

- Be sure that your vehicle is parked outside of the garage before you begin programming.
- For more efficient programming and accurate transmission of the radio-frequency signal it is recommended that a new battery be placed in the hand-held transmitter of the device that is being programmed to the HomeLink® system.



ELECTRONICS

- Erase all channels before you begin programming. To erase the channels, place the ignition switch into the ON/RUN position, then press and hold the two outside HomeLink® buttons (I and III) for up 20 seconds or until the red indicator flashes.

NOTE:

- Erasing all channels should only be performed when programming HomeLink® for the first time. Do not erase channels when programming additional buttons.
- If you have any problems, or require assistance, please call toll-free 1-800-355-3515 or, on the Internet at www.HomeLink.com for information or assistance.

Programming A Rolling Code

- For programming Garage Door Openers that were manufactured after 1995. These Garage Door Openers can be identified by the “LEARN” or “TRAIN” button located where the hanging antenna is attached to the Garage Door Opener. It is NOT the button that is normally used to open and close the door. The name and color of the button may vary by manufacturer.
- Place the ignition switch into the ON/RUN position.
- Place the hand-held transmitter 1 to 3 in (3 to 8 cm) away from the HomeLink® button you wish to program while keeping the HomeLink® indicator light in view.
- Simultaneously press and hold both the HomeLink® button you want to program and the hand-held transmitter button.
- Continue to hold both buttons and observe the indicator light. The Homelink® indicator will flash slowly and then rapidly after Homelink® has received the frequency signal from the hand-held transmitter. Release both buttons after the indicator light changes from slow to rapid.
- At the garage door opener motor (in the garage), locate the “LEARN” or “TRAINING” button. This can usually be found where the hanging antenna wire is attached to the garage door opener motor. Firmly press and release the “LEARN” or “TRAINING” button.

NOTE: You have 30 seconds in which to initiate the next step after the LEARN button has been pressed.

- Return to the vehicle and press the programmed HomeLink® button twice (holding the button for two seconds each time). If the device is plugged in and activates, programming is complete.

NOTE: If the device does not activate, press the button a third time (for two seconds) to complete the training.

- To program the remaining two HomeLink® buttons, repeat each step for each remaining button. DO NOT erase the channels.

ELECTRONICS

Programming A Non-Rolling Code

- For programming Garage Door Openers manufactured before 1995.
- Turn the ignition switch to the ON/RUN position.
- Place the hand-held transmitter 1 to 3 in (3 to 8 cm) away from the HomeLink® button you wish to program while keeping the HomeLink® indicator light in view.
- Simultaneously press and hold both the HomeLink® button you want to program and the hand-held transmitter button.
- Continue to hold both buttons and observe the indicator light. The Homelink® indicator will flash slowly and then rapidly after Homelink® has received the frequency signal from the hand-held transmitter. Release both buttons after the indicator light changes from slow to rapid.
- Press and hold the programmed HomeLink® button and observe the indicator light.

NOTE:

- If the indicator light stays on constantly, programming is complete and the garage door (or device) should activate when the HomeLink® button is pressed.
- To program the two remaining HomeLink® buttons, repeat each step for each remaining button. DO NOT erase the channels.

Using HomeLink®

- To operate, press and release the programmed HomeLink® button. Activation will now occur for the programmed device (i.e., garage door opener, gate operator, security system, entry door lock, home/office lighting, etc.,). The hand-held transmitter of the device may also be used at any time.

WARNING!

- Your motorized door or gate will open and close while you are programming the universal transceiver. Do not program the transceiver if people or pets are in the path of the door or gate.
- Do not run your vehicle in a closed garage or confined area while programming the transceiver. Exhaust gas from your vehicle contains Carbon Monoxide (CO) which is odorless and colorless. Carbon Monoxide is poisonous when inhaled and can cause you and others to be severely injured or killed.

ELECTRONICS

POWER INVERTER

- There is a 115 Volt, 150 Watt power inverter outlet located on the back of the center console. This outlet can power cellular phones, electronics and other low power devices requiring power up to 150 Watts.
- Press the switch located in the switch bank on the lower instrument panel to turn the power inverter on. The indicator light will turn on to indicate the inverter is producing AC power.
- Press the switch again to turn the power inverter off. The indicator light will turn off.



NOTE: The power inverter is designed with built-in overload protection. If the power rating of 150 Watts is exceeded, the power inverter will automatically shut down. Once the electrical device has been removed from the outlet, the inverter should automatically reset. If the power rating exceeds approximately 170 Watts, the power inverter may have to be reset manually. To reset the inverter manually, unplug the device and plug it in again. To avoid overloading the circuit, check the power ratings on electrical devices prior to using the inverter.

WARNING!

To Avoid Serious Injury or Death: Do not use a three-prong adaptor. Do not insert any objects into the receptacles. Do not touch with wet hands. Close the lid when not in use. If this outlet is mishandled, it may cause an electric shock and failure.

POWER OUTLETS

- The front power outlet is located inside the center storage bin of the instrument panel. Push inward on the storage lid to open the compartment and gain access to this power outlet.
- A second front power outlet is located inside the center console.
- The rear power outlet is located in the right rear cargo area.



ELECTRONICS

- The power outlets are labeled with either a “key” or a “battery” symbol to indicate how the outlet is powered. Power outlets labeled with a “key” are powered when the ignition switch is in the ON/RUN or ACC position, while the outlets labeled with a “battery” are connected directly to the battery and powered at all times.

NOTE:

- Do not exceed the maximum power of 160 Watts (13 Amps) at 12 Volts. If the 160 Watt (13 Amp) power rating is exceeded, the fuse protecting the system will need to be replaced.
- Power outlets are designed for accessory plugs only. Do not insert any other object in the power outlet as this will damage the outlet and blow the fuse. Improper use of the power outlet can cause damage not covered by your new vehicle warranty.
- The rear cargo power outlet can be switched to “battery” powered all the time by switching the power outlet right rear quarter panel fuse in the fuse panel.

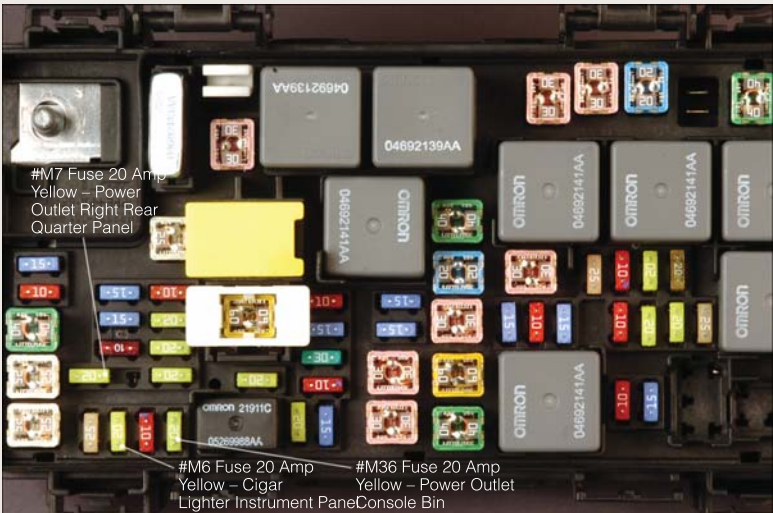
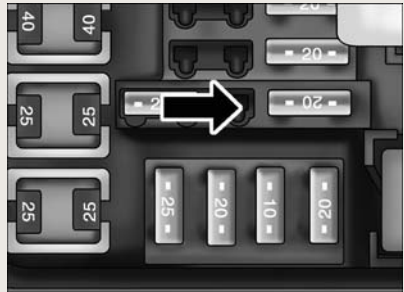

OFF-ROAD CAPABILITIES

QUADRA-TRAC I® FOUR-WHEEL DRIVE

Quadra-Trac I® Operating Instructions/Precautions - 3.6L Only

- The Quadra-Trac I® is a single-speed (HI range only) transfer case, which provides convenient full-time four-wheel drive. No driver interaction is required. The Brake Traction Control (BTC) System, which combines standard ABS and Traction Control, provides resistance to any wheel that is slipping to allow additional torque transfer to wheels with traction.

QUADRA-TRAC II®/QUADRA-DRIVE II® FOUR-WHEEL DRIVE

Quadra-Trac II®/Quadra-Drive II® Operating Instructions/Precautions

- The Quadra-Trac II®/Quadra-Drive II® transfer case is fully automatic in the normal driving 4WD HI mode. The Quadra-Trac II®/Quadra-Drive II® transfer case provides three mode positions:
 - 4WD HI
 - NEUTRAL
 - 4WD LOW
- This transfer case is fully automatic in the 4WD HI mode.



- When additional traction is required, the 4WD LOW position can be used to lock the front and rear driveshafts together and force the front and rear wheels to rotate at the same speed. The 4WD LOW position is intended for loose, slippery surfaces only. Driving in the 4WD LOW position on dry, hard-surfaced roads may cause increased tire wear and damage to driveline components.
- When operating your vehicle in 4WD LOW, the engine speed is approximately three times that of the 4WD HI position at a given road speed. Take care not to overspeed the engine and do not exceed 25 mph (40 km/h).

NOTE:

- If shift conditions/interlocks are not met, or a transfer case motor temperature protection condition exists, a "For 4x4 Low Slow Below 5 MPH or 8 KPH Put Trans in N Press 4 Low" message will flash from the Electronic Vehicle Information Center (EVIC).

OFF-ROAD CAPABILITIES

Shifting Procedures

4WD HI To 4WD LOW

- With the vehicle at speeds of 0 to 3 mph (0 to 5 km/h), the ignition switch in the ON/RUN position or the engine running, shift the transmission into NEUTRAL, and press the “4WD LOW” button once on the transfer case switch. The “4WD LOW” indicator light in the instrument cluster will begin to flash and remain on solid when the shift is complete.

4WD LOW To 4WD HI

- With the vehicle at speeds of 0 to 3 mph (0 to 5 km/h), the ignition switch in the ON/RUN position or the engine running, shift the transmission into NEUTRAL, and press the “4WD LOW” button once on the transfer case switch. The “4WD LOW” indicator light in the instrument cluster will flash and turn off when the shift is complete.

NOTE:

- If the shift conditions/interlocks are not met, or a transfer case motor temperature protection exists, a “For 4x4 Low Slow Below 5 MPH or 8 KPH Put Trans in N Press 4 Low” message will flash on the Electronic Vehicle Information Center (EVIC).
- Shifting into or out of 4WD LOW is possible with the vehicle completely stopped; however, difficulty may occur due to the mating clutch teeth not being properly aligned. Several attempts may be required for clutch teeth alignment and shift completion to occur. The preferred method is with the vehicle rolling 0 to 3 mph (0 to 5 km/h). If the vehicle is moving faster than 3 mph (5 km/h), the transfer case will not allow the shift.

NEUTRAL Shift Procedure

- Turn the ignition switch to the ON/RUN position, engine off.
- Vehicle stopped, with foot on brake.
- Place the transmission into NEUTRAL.
- Press and hold the NEUTRAL button located near the 4WD mode control knob with a pen or similar object for four seconds. The indicator light will begin to flash indicating the shift is in progress. The light will stop blinking (stay on solid) when the NEUTRAL shift is complete. A “4WD SYSTEM IN NEUTRAL” message will display on the Electronic Vehicle Information Center (EVIC).
- Repeat these Steps to shift out of NEUTRAL.

OFF-ROAD CAPABILITIES

SELEC-TERRAIN™

- Selec-Terrain™ combines the capabilities of the vehicle control systems, along with driver input, to provide the best performance for all terrains.

Rotate the mode control knob to select the following Selec-Terrain™ positions:

- **Sport** – Dry weather, on-road calibration. Only available in 4WD High range. Performance-based tuning that provides a rear wheel drive feel but with improved handling and acceleration over a two-wheel drive vehicle. The Electronic Stability Control will set to allow more driver control of the vehicle while maintaining safe handling controls. The vehicle will lower (if equipped with Air Suspension) by 0.59 inches (15 mm) in the SPORT mode.
- **Snow** – The Electronic Stability Control is set for additional stability in inclement weather. Use on and off road on loose traction surfaces such as snow.
- **Auto** – Fully automatic full-time four-wheel drive operation can be used on and off road. Balances traction with steering feel to provide improved handling and acceleration over two-wheel drive vehicles.
- **Sand/Mud** – Off-road calibration for use on low traction surfaces such as mud, sand, or wet grass. Driveline is maximized for traction. Some binding may be felt on less forgiving surfaces. The electronic brake controls are set to limit traction control management of throttle and wheel spin.
- **Rock** – Off-road calibration only available in 4WD Low range. The vehicle is raised (if equipped with Air Suspension) for improved ground clearance. Traction based tuning with improved steer-ability for use on high traction off-road surfaces. Activates the Hill Descent Control for steep downhill control. Use for low speed obstacles such as large rocks, deep ruts, etc.

Quadra-Lift™

- The Quadra-Lift™ air suspension system provides full time load leveling capability along with the benefit of being able to adjust vehicle height by the push of a button. Quadra-Lift™ is available with both Quadra-Trac II® and Quadra-Drive II™.
- The system requires that the engine be running for all changes. When lowering the vehicle all of the doors, including the liftgate, must be closed.



OFF-ROAD CAPABILITIES

- The Quadra-Lift™ air suspension system uses a lifting and lowering pattern which keeps the headlights from shining into oncoming traffic. When raising the vehicle, the rear of the vehicle will move up first and then the front. When lowering the vehicle, the front will move down first and then the rear.
- After the engine is turned off, you may notice that the air suspension system operates briefly. This is normal. The system is correcting the position of the vehicle.
- To assist with changing a spare tire, the Quadra-Lift™ air suspension system has a feature which allows the automatic leveling to be disabled. Press and hold both the “Up” and “Down” buttons simultaneously between 5 and 10 seconds; a message will appear in the EVIC stating leveling has been disabled immediately after both buttons have been released. Driving the vehicle over 5 mph (8 km/h) will return the air suspension to normal operation.
- An audible chime will be heard whenever a system error has been detected.

Operation

- Pressing the “Up” or “Down” button once will move the suspension one position higher or lower from the current position, assuming all conditions are met (i.e., engine running and all doors and liftgate closed).
- The 4 indicator lamps will illuminate to show the current position of the vehicle. Flashing indicator lamps will show a position which the system is working to achieve. If multiple indicator lamps are flashing on the “Up” button, the highest flashing indicator lamp is the position the system is working to achieve.



- • Normal Ride Height (NRH) – This is the standard position of the suspension and is meant for normal driving. Only the bottom Indicator lamp on the “Up” button will be illuminated when the vehicle is in this position.



- • Off-Road 1 (OR1) (Raises the vehicle approximately 1.3 in (33 mm) – This position is intended for off-road driving only where vehicle speeds may go above 25 mph (40 km/h). Press the “Up” button once from NRH while vehicle speed is below 48 mph (77 km/h). The bottom two Indicator lamps on the “Up” button will be illuminated when the vehicle is in OR1.



- • Off-Road 2 (OR2) (Raises the vehicle approximately 2.6 in (65 mm) – This position is intended for off-road driving where maximum ground clearance is required. Press the “Up” button twice from NRH, or once from OR1 position while vehicle speed is below 20 mph (32 km/h). All three Indicator lamps on the “Up” button will be illuminated when the vehicle is in OR2.

OFF-ROAD CAPABILITIES



- Park Mode (Lowers the vehicle approximately 1.5 in (38 mm) – This position lowers the vehicle for easier passenger entry and exit. Press the “Down” button once from NRH while the vehicle speed is below 25 mph (40 km/h). Once the vehicle speed goes below 15 mph (24 km/h) the vehicle height will begin to lower. The Indicator lamp on the “Down” button will be

illuminated when the vehicle is in Park Mode.

WARNING!

- You or others could be injured if you leave the vehicle unattended with the transfer case in the N (Neutral) position without first fully engaging the parking brake. The transfer case N (Neutral) position disengages both the front and rear driveshafts from the powertrain and will allow the vehicle to move regardless of the transmission position. The parking brake should always be applied when the driver is not in the vehicle.
- The air suspension system uses a high pressure volume of air to operate the system. To avoid personal injury or damage to the system, see your authorized dealer for service.

Hill Start Assist/Hill Descent Control

- The Hill Start Assist system assists the driver when starting a vehicle from a stop on a hill.
- The Hill Descent Control system maintains vehicle speed while descending hills during off-road driving situations and is available in 4WD HIGH range and 4WD LOW range.
- Refer to your Owner’s Manual on the DVD for further details.

UTILITY

TRAILER TOWING WEIGHTS (MAXIMUM TRAILER WEIGHT RATINGS)

Engine/Model	Model	GCWR (Gross Combined Wt. Rating)	Frontal Area	Max. GTW (Gross Trailer Wt.)	Max. Trailer Tongue Wt. (See Note)
3.6L	4x2	10,400 lbs. (4 717 kg)	40 sq ft (3.72 sq m)	5,000 lbs (2 268 kg)	500 lbs (227 kg)
3.6L	4x4	10,400 lbs. (4 717 kg)	40 sq ft (3.72 sq m)	5,000 lbs (2 268 kg)	500 lbs (227 kg)
5.7L	4x2	13,100 lbs (5 942 kg)	60 sq ft (5.57 sq m)	7,400 lbs (3 357 kg)	740 lbs (336 kg)
5.7L	4x4	13,100 lbs (5 942 kg)	60 sq ft (5.57 sq m)	7,200 lbs (3 266 kg)	720 lbs (327 kg)
6.4L *	SRT8	10,400 lbs (4 717 kg)	40 sq ft (3.72 sq m)	5,000 lbs (2 268 kg)	500 lbs (227 kg)

* For SRT8 vehicles, do not tow a trailer when using the compact spare tire. Refer to local laws for maximum trailer towing speeds.

NOTE: The trailer tongue weight must be considered as part of the combined weight of occupants and cargo, and should never exceed the weight referenced on the Tire and Loading Information placard.

- If the gross trailer weight is 3,500 lbs (1587 kg) or more, it is mandatory to use a weight-distributing hitch to ensure stable handling of your vehicle.

NOTE: Vehicles not factory equipped with trailer tow package are limited to 3,500 lbs (350 lbs tongue weight).

TOW/HAUL MODE

- When driving in hilly areas, towing a trailer, carrying a heavy load, etc., and frequent transmission shifting occurs, press the TOW/HAUL switch to select TOW/HAUL mode. This will improve performance and reduce the potential for transmission overheating or failure due to excessive shifting. When operating in TOW/HAUL mode, transmission upshifts are delayed, and the transmission will automatically downshift (for engine braking) during steady braking maneuvers.
- The “TOW/HAUL Indicator Light” will illuminate in the instrument cluster to indicate that TOW/HAUL mode has been activated. Pressing the switch a second time restores normal operation. If the TOW/HAUL mode is desired, the switch must be pressed each time the engine is started.



TOW/HAUL Switch

RECREATIONAL TOWING (BEHIND MOTORHOME, ETC.)

Two-Wheel Drive Models

- **Recreational towing is not allowed.**

Quadra-Trac I® (Single-Speed Transfer Case) Four-Wheel Drive Models

- **Recreational towing is not allowed.** This model does not have a NEUTRAL position in the transfer case.

Quadra-Trac II® /Quadra-Drive® II /Selec- Terrain™ Four-Wheel Drive Models

NOTE: The transfer case must be in the NEUTRAL position, and the transmission must be in the PARK position for recreational towing.

Shifting Into NEUTRAL

- Use the following procedure to prepare your vehicle for recreational towing.
- Bring the vehicle to a complete stop and shift the transmission to PARK. Turn the engine off.

UTILITY

- For vehicles with Keyless Enter-N-Go™, remove the Keyless Enter-N-Go™ button and use the Key Fob to complete this procedure.
- Turn the ignition switch to the ON/RUN position, but do not start the engine.
- Press and hold the brake pedal and shift the transmission into NEUTRAL.
- Using a ballpoint pen or similar object, press and hold the recessed transfer case N (Neutral) button for four seconds, until the light next to the N symbol starts to blink, indicating shift in progress. The light will stop blinking (stay on solid) when the shift to N (Neutral) is complete. A “FOUR WHEEL DRIVE SYSTEM IN NEUTRAL” message will display on the EVIC (Electronic Vehicle Information Center).
- Start the engine and shift the transmission into REVERSE.
- Release the brake pedal for five seconds and ensure that there is no vehicle movement.
- Turn the engine off and firmly apply the parking brake.
- Shift the transmission into PARK and remove the Key Fob.
- Attach the vehicle to the tow vehicle using a suitable tow bar and release the parking brake.

NOTE: Vehicles equipped with Quadra-Lift™ must be lowered to the “Park” (lowest) level, and have automatic leveling disabled, before tying them down (from the body) on a trailer or a flatbed truck. Refer to “Quadra-Lift™” in “Off-Road Capabilities” for more information. If the vehicle cannot be lowered to the “Park” level (for example, engine will not run), tie-downs must be fastened to the axles (not the body). Failure to follow these instructions may cause fault codes to be set and/or loss of proper tie-down tension.

CAUTION!

- Towing with the rear wheels on the ground will cause severe transmission damage. Damage from improper towing is not covered under the New Vehicle Limited Warranty.
- Front or rear wheel lifts should not be used. Internal damage to the transmission or transfer case will occur if a front or rear wheel lift is used when recreational towing.
- It is necessary to follow these steps to be certain that the transfer case is fully in NEUTRAL before recreational towing to prevent damage to internal parts.

WARNING!

You or others could be injured if you leave the vehicle unattended with the transfer case in the NEUTRAL position without first fully engaging the parking brake. The transfer case NEUTRAL position disengages both the front and rear driveshafts from the powertrain and will allow the vehicle to move even if the transmission is in PARK. The parking brake should always be applied when the driver is not in the vehicle.

SRT8

AUTOSTICK®

- AutoStick® is a driver-interactive transmission feature that offers manual gear shifting to provide you with more control of the vehicle. AutoStick® allows you to maximize engine braking, eliminate undesirable upshifts and downshifts, and improve overall vehicle performance.
- This system can also provide you with more control during passing, city driving, cold slippery conditions, mountain driving, trailer towing, and many other situations.



Operation

- When the shift lever is in the DRIVE position, the transmission will operate automatically, shifting between the five available gears. To engage AutoStick®, simply tap the shift lever to the right or left (+/-) while in the DRIVE position, or tap one of the steering wheel-mounted shift paddles (+/-). Tapping (-) to enter AutoStick® mode will downshift the transmission to the next lower gear, while using (+) to enter AutoStick® mode will retain the current gear. When AutoStick® is active, the current transmission gear is displayed in the instrument cluster. In AutoStick® mode, the transmission will shift up or down when (+/-) is manually selected by the driver (using the shift lever, or the shift paddles), unless an engine lugging or overspeed condition would result. It will remain in the selected gear until another upshift or downshift is chosen, except as described below:
- Normally, in AutoStick® mode, the transmission will automatically shift up when maximum engine speed is reached. If, however, AutoStick® is engaged while in SPORT mode, the transmission will remain in the selected gear even when maximum engine speed is reached. The transmission will upshift only when commanded by the driver.
- The transmission will automatically downshift as the vehicle slows (to prevent engine lugging) and will display the current gear.
- The transmission will automatically downshift to first gear when coming to a stop. After a stop, the driver should manually upshift (+) the transmission as the vehicle is accelerated.
- You can start out in first or second gear. Tapping (+) (at a stop) will allow starting in second gear. Starting out in second gear is helpful in snowy or icy conditions.
- The system will ignore attempts to upshift at too low of a vehicle speed.
- Avoid using speed control when AutoStick® is engaged.

- Transmission shifting will be more noticeable when AutoStick® is engaged.
- To disengage AutoStick® mode, hold the shift lever to the right or press and hold the (+) shift paddle until “D” is once again displayed in the instrument cluster. You can shift in or out of the AutoStick® mode at any time without taking your foot off the accelerator pedal.

WARNING!

Do not downshift for additional engine braking on a slippery surface. The drive wheels could lose their grip and the vehicle could skid, causing a collision or personal injury.

SELEC-TRACK™

- Selec-Track™ combines the capabilities of the vehicle control systems, along with driver input, to provide the best performance for all terrains.

- Rotate the mode control knob to select the following Selec-Track™ positions:

- **Sport** - Dry weather, on-road calibration. Performance based tuning that provides a rear wheel drive feel but with improved handling and acceleration over a two-wheel drive vehicle. The active suspension system will be in Semi Firm mode, and a green flag will light up in the instrument cluster.

- **Snow** - Tuning set for additional stability in inclement weather. Use on and off road on loose traction surfaces such as snow.

- **Auto** - Fully automatic full time four-wheel drive operation can be used on and off road. This position balances traction with seamless steering feel to provide improved handling and acceleration over two-wheel drive vehicles.

- **Track** - This position offers track road calibration for use on high traction surfaces. Driveline is maximized for traction. Some binding may be felt on less forgiving surfaces.

- **Tow** - Use this mode for towing. Vehicle suspension will go to Firm mode and peak power will be limited in the engine controls.

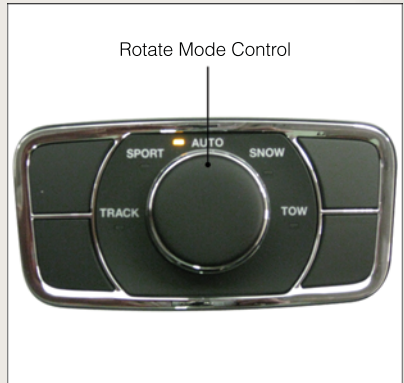

SRT8

PERFORMANCE FEATURES

Electronic Vehicle Information Center (EVIC) - If Equipped

- The EVIC can be used to program the following Performance Features. Press the UP Δ or DOWN ∇ button until Performance Features displays, then press the SELECT \triangleright button. Scroll through the settings using the UP or DOWN buttons. Press the SELECT \triangleright button to change the setting. Press the BACK button to scroll back to a previous menu or sub menu.



- 0-60 mph (0-100 km/h)
- Braking Distance
- 1/8 Mile
- 1/4 Mile
- Instantaneous G-Force
- Peak G-Force
- Digital Speedometer

0-60 mph (0-100 km/h)

- When selected, this screen displays the time it takes for the vehicle to go from 0 to 60 mph (0 to 100 km/h) within 10 seconds.

Braking Distance

- When selected, this screen displays the vehicle's braking distance and the speed at which the brake pedal was depressed.

1/8 Mile, 1/4 Mile

- When selected, this screen displays the time it takes the vehicle to travel 1/8 mile (1/4 mile) within 30 seconds and the vehicle's speed when it reaches 1/8 mile (1/4 mile).

Instantaneous G-Force

- When selected, this screen displays the current G-Force (lateral and longitudinal) along with a friction circle that displays the directions of the forces.

Peak G-Force

- When selected, this screen displays all four G-Force values (two lateral and two longitudinal).

Digital Speedometer

- When selected, this screen displays vehicle speed and records top speed.

WARNING!

Measurement of vehicle statistics with the Performance Features is intended for off-highway or off-road use only and should not be done on any public roadways. It is recommended that these features be used in a controlled environment and within the limits of the law. The capabilities of the vehicle as measured by the performance pages must never be exploited in a reckless or dangerous manner, which can jeopardize the user's safety or the safety of others. Only a safe, attentive, and skillful driver can prevent accidents.

SUMMER/THREE-SEASON TIRES

- This vehicle may be equipped with wheels and tires to enhance traction in both wet and dry conditions.
- Summer tires are not intended to be driven in snow or on ice.
- Use summer tires only in sets of four.

NOTE: Summer tires will not contain the all season designation or mountain/snowflake symbol on the sidewall of the tire.

WARNING!

Do not use summer tires in snow/ice conditions. You could lose control, resulting in severe injury or death.

WHAT TO DO IN EMERGENCIES

24-HOUR TOWING ASSISTANCE

- Dial toll-free 1-800-521-2779 or 1-800-363-4869 for Canadian residents.
- Provide your name, vehicle identification number and license plate number.
- Provide your location, including telephone number, from which you are calling.
- Briefly describe the nature of the problem and answer a few simple questions.
- You will be given the name of the service provider and an estimated time of arrival. If you feel you are in an “unsafe situation”, please let us know. With your consent, we will contact local police or safety authorities.

INSTRUMENT CLUSTER WARNING LIGHTS

- Tire Pressure Monitoring System (TPMS) Light

- Each tire, including the spare (if provided), should be checked monthly, when cold and inflated to the inflation pressure recommended by the vehicle manufacturer on the vehicle placard or tire inflation pressure label. (If your vehicle has tires of a different size than the size indicated on the vehicle placard or tire inflation pressure label, you should determine the proper tire inflation pressure for those tires.)
- As an added safety feature, your vehicle has been equipped with a Tire Pressure Monitoring System (TPMS) that illuminates a low tire pressure telltale when one or more of your tires is significantly under-inflated. Accordingly, when the low tire pressure telltale illuminates, you should stop and check your tires as soon as possible, and inflate them to the proper pressure. Driving on a significantly under-inflated tire causes the tire to overheat and can lead to tire failure. Under-inflation also reduces fuel efficiency and tire tread life, and may affect the vehicle’s handling and stopping ability.
- **IF THE LIGHT STARTS FLASHING INDICATING A LOW TIRE PRESSURE, ADJUST THE AIR PRESSURE IN THE LOW TIRE TO THE AIR PRESSURE SHOWN ON THE VEHICLE PLACARD OR TIRE INFLATION PRESSURE LABEL LOCATED ON THE DRIVER’S DOOR. NOTE: AFTER INFLATION, THE VEHICLE MAY NEED TO BE DRIVEN FOR 20 MINUTES BEFORE THE FLASHING LIGHT WILL TURN OFF.**
- Please note that the TPMS is not a substitute for proper tire maintenance, and it is the driver’s responsibility to maintain correct tire pressure, even if under-inflation has not reached the level to trigger illumination of the TPMS low tire pressure telltale.

WHAT TO DO IN EMERGENCIES

- Your vehicle has also been equipped with a TPMS malfunction indicator to indicate when the system is not operating properly. The TPMS malfunction indicator is combined with the low tire pressure telltale. When the system detects a malfunction, the telltale will flash for approximately one minute and then remain continuously illuminated. This sequence will continue each time the vehicle is restarted as long as the malfunction exists.
- When the malfunction indicator is illuminated, the system may not be able to detect or signal low tire pressure as intended. TPMS malfunctions may occur for a variety of reasons, including the installation of replacement or alternate tires or wheels on the vehicle that prevent the TPMS from functioning properly. Always check the TPMS malfunction telltale after replacing one or more tires or wheels on your vehicle, to ensure that the replacement or alternate tires and wheels allow the TPMS to continue to function properly.

NOTE: Tire pressures change by approximately 1 psi (7 kPa) per 12° F (7° C) of air temperature change. Keep this in mind when checking tire pressure inside a garage, especially in the Winter. Example: If garage temperature is 68°F (20°C) and the outside temperature is 32°F (0°C), then the cold tire inflation pressure should be increased by 3 psi (21 kPa), which equals 1 psi (7 kPa) for every 12°F (7°C) for this outside temperature condition.

CAUTION!

The TPMS has been optimized for the original equipment tires and wheels. TPMS pressures and warning have been established for the tire size equipped on your vehicle. Undesirable system operation or sensor damage may result when using replacement equipment that is not of the same size, type, and/or style. Aftermarket wheels can cause sensor damage. Do not use tire sealant from a can, or balance beads if your vehicle is equipped with a TPMS, as damage to the sensors may result.

BRAKE - Brake Warning Light

- The Brake Warning light illuminates when there is either a system malfunction or the parking brake is applied. If the light is on and the parking brake is not applied, it indicates a possible brake hydraulic malfunction, brake booster problem or an Anti-Lock Brake System problem.
- Please have your vehicle serviced immediately.

WARNING!

Driving a vehicle with the red brake light on is dangerous. Part of the brake system may have failed. It will take longer to stop the vehicle. You could have a collision. Have the vehicle checked immediately.

WHAT TO DO IN EMERGENCIES



- Malfunction Indicator Light (MIL)

- Certain conditions, such as a loose or missing gas cap, poor fuel quality, etc., may illuminate the MIL after engine start. The vehicle should be serviced if the light stays on through several typical driving cycles. In most situations, the vehicle will drive normally and not require towing.
- If the MIL flashes when the engine is running, serious conditions may exist that could lead to immediate loss of power or severe catalytic converter damage. We recommend you do not operate the vehicle. Have the vehicle serviced immediately.



- Electronic Stability Control (ESC) Activation/Malfunction Indicator Light

- If the “ESC Activation/Malfunction Indicator Light” comes on continuously with the engine running, a malfunction has been detected in the ESC system. If this light remains on after several ignition cycles, and the vehicle has been driven several miles (kilometers) at speeds greater than 30 mph (48 km/h), we recommend you drive to the nearest service center and have the vehicle serviced immediately.
- The “ESC Activation/Malfunction Indicator Light” starts to flash as soon as the tires lose traction and the ESC system becomes active. If the light begins to flash during acceleration, ease up on the accelerator and apply as little throttle as possible. Be sure to adapt your speed and driving to the prevailing road conditions. The light also flashes when TCS is active. To improve the vehicle’s traction when starting off in deep snow, sand or gravel, it may be desirable to switch the ESC system to Partial Off mode by momentarily pressing the ESC Off  switch located below the climate controls, on the switch panel.



- Charging System Light

- This light shows the status of the electrical charging system. If the charging system light remains on, it means that the vehicle is experiencing a problem with the charging system.
- We recommend you do not continue driving if the charging system light is on. Have the vehicle serviced immediately.



- Oil Pressure Warning Light

- This light indicates low engine oil pressure. If the light turns on while driving, stop the vehicle and shut off the engine as soon as possible. A chime will sound for four minutes when this light turns on.
- We recommend you do not operate the vehicle or engine damage will occur. Have the vehicle serviced immediately.



- Anti-Lock Brake (ABS) Light

- This light monitors the Anti-Lock Brake System (ABS).
- If the light is not on during starting, stays on, or turns on while driving, we recommend you drive to the nearest service center and have the vehicle serviced immediately.

WHAT TO DO IN EMERGENCIES

- **Electronic Throttle Control (ETC) Light**

- This light informs you of a problem with the Electronic Throttle Control (ETC) system.
- If a problem is detected, the light will come on while the engine is running. Cycle the ignition key when the vehicle has completely stopped and the shift lever is placed in the PARK position; the light should turn off.
- If the light remains lit with the engine running, your vehicle will usually be drivable; however, see an authorized service center immediately. If the light is flashing when the engine is running, immediate service is required and you may experience reduced performance, an elevated/rough idle or engine stall and your vehicle may require towing.

- **Air Bag Warning Light**

- If the light is not on during starting, stays on, or turns on while driving, have the vehicle serviced by an authorized service center immediately.

Fuel Cap/Loose Gas Cap Message

- If a “gas cap” message (shown as Check GasCap) appears, tighten the gas cap until a “clicking” sound is heard.
- If the message continues to appear for more than three days after tightening the gas cap, have the vehicle serviced by an authorized service center immediately.

Oil Change Indicator Message

- If an “oil change” message (shown as Oil Change Required) appears and a single chime sounds, it is time for your next required oil change.

Resetting The Light After Servicing Vehicles Equipped With Keyless Enter-N-Go™

- Without pressing the brake pedal, push the ENGINE START/STOP button and cycle the ignition to the ON/RUN position (Do not start the engine.)
- Fully depress the accelerator pedal, slowly, three times within 10 seconds.
- Without pressing the brake pedal, push the ENGINE START/STOP button once to return the ignition to the OFF/LOCK position.

Vehicles Not Equipped With Keyless Enter-N-Go™

- Turn the ignition switch to the ON/RUN position (Do not start the engine.)
- Fully depress the accelerator pedal, slowly, three times within 10 seconds.
- Turn the ignition switch to the OFF/LOCK position.

WHAT TO DO IN EMERGENCIES

IF YOUR ENGINE OVERHEATS

- In any of the following situations, you can reduce the potential for overheating by taking the appropriate action.
- On the highways – slow down.
- In city traffic – while stopped, place the transmission in NEUTRAL, but do not increase engine idle speed.

NOTE: There are steps that you can take to slow down an impending overheat condition:

- If your air conditioner (A/C) is on, turn it off. The A/C system adds heat to the engine cooling system and turning the A/C off can help remove this heat.
- You can also turn the temperature control to maximum heat, the mode control to floor and the blower control to high. This allows the heater core to act as a supplement to the radiator and aids in removing heat from the engine cooling system.

CAUTION!

Driving with a hot cooling system could damage your vehicle. If the temperature gauge reads 240°F (116 °C) or greater pull over and stop the vehicle. Idle the vehicle with the air conditioner turned off until the pointer drops back into the normal range 200–230°F (93–110°C). If the pointer remains at 240°F (116°C) or greater and you hear a chime, turn the engine off immediately and call for service.

WARNING!

You or others can be badly burned by hot engine coolant (antifreeze) or steam from your radiator. If you see or hear steam coming from under the hood, do not open the hood until the radiator has had time to cool. Never try to open a cooling system pressure cap when the radiator or coolant bottle is hot.

WHAT TO DO IN EMERGENCIES

JACKING AND TIRE CHANGING

Run Flat Tires - SRT8 Only

- This vehicle is equipped with a compact spare along with run flat tires. Although the tires are designed with a “run flat” feature that allows the vehicle to be driven approximately 50 miles (80 km) at 55 mph (88 km/h), immediate service should be obtained.

NOTE: The compact spare tire is to be used for rear wheel(s) only. For a flat front tire, move the rear tire to the front and use the compact spare on the rear.

WARNING!

- Do not exceed 50 mph (80 km/h) if the “Tire Pressure Monitoring Telltale Light” is illuminated. Vehicle handling and braking may be reduced. You could have a collision and be severely or fatally injured.
- Do not tow a trailer when using the compact spare tire.

WHAT TO DO IN EMERGENCIES

Jack Location

- The scissor-type jack and tire changing tools are located in rear cargo area, below the load floor.



Spare Tire Stowage

- The spare tire is stowed under the load floor in the rear cargo area and is secured to the body with a special wing nut.

WHAT TO DO IN EMERGENCIES

Preparations For Jacking

1. Park the vehicle on a firm, level surface. Avoid ice or slippery surfaces.
2. Turn on the Hazard Warning flasher.
3. Set the parking brake.
4. Place the shift lever into PARK.
5. Turn the ignition OFF.
6. For vehicle equipped with Quadra-Lift® refer to “Quadra-Lift – If Equipped” in “Starting And Operating” on the DVD for further information on disabling automatic leveling.

Block both the front and rear of the wheel diagonally opposite of the jacking position. For example, if changing the right front tire, block the left rear wheel.

NOTE: Passengers should not remain in the vehicle when the vehicle is being jacked.

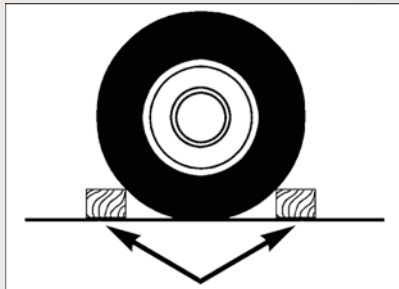

Jacking Instructions

1. Remove the spare tire, jack, and tools from storage.
2. Loosen (but do not remove) the wheel lug nuts by turning them to the left, one turn, while the wheel is still on the ground.
3. Assemble the jack and jacking tools.



WHAT TO DO IN EMERGENCIES

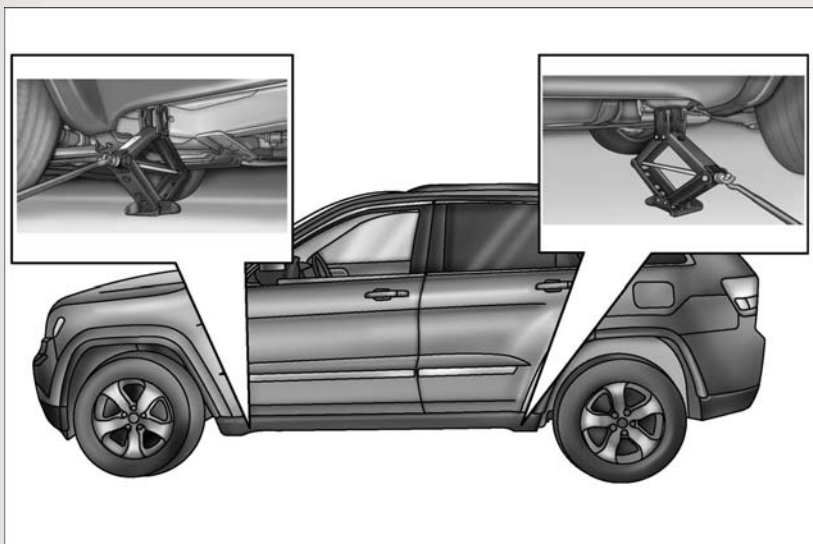

4. For the front axle, place the jack on the body flange just behind the front tire as indicated by the triangular lift point symbol on the sill molding. **Do not raise the vehicle until you are sure the jack is fully engaged.**
5. For a rear tire, place the jack in the slot on the rear tie-down bracket, just forward of the rear tire (as indicated by the triangular lift point symbol on the sill molding). **Do not raise the vehicle until you are sure the jack is fully engaged.**



WHAT TO DO IN EMERGENCIES

6. Raise the vehicle by turning the jack screw clockwise. Raise the vehicle only until the tire just clears the surface and enough clearance is obtained to install the spare tire. Minimum tire lift provides maximum stability.
7. Remove the lug nuts and wheel.
8. Position the spare wheel/tire on the vehicle and install the lug nuts with the cone-shaped end toward the wheel. Lightly tighten the nuts.
9. Lower the vehicle by turning the jack screw counterclockwise, and remove the jack and wheel blocks.
10. Finish tightening the lug nuts. Push down on the wrench while at the end of the handle for increased leverage. Tighten the lug nuts in a star pattern until each nut has been tightened twice. The correct wheel nut tightness is 110 ft lbs (150 N·m). If in doubt about the correct tightness, have them checked with a torque wrench by your authorized dealer or at a service station.
11. Lower the jack to the fully closed position and return it and the tools to the proper positions in the foam tray.
12. Remove the small center cap and securely store the road wheel in the cargo area.
13. Have the aluminum road wheel and tire repaired as soon as possible, properly secure the spare tire with the special wing nut torqued to 3.7 ft-lbs (5 N·m), reinstall the jack and tool kit foam tray, and latch the rear load floor cover.

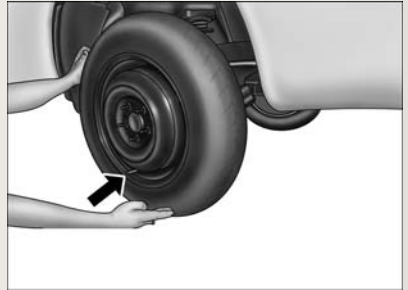

WHAT TO DO IN EMERGENCIES

Road Tire Installation

1. Mount the road tire on the axle.
2. Install the remaining lug nuts with the cone shaped end of the nut toward the wheel. Lightly tighten the lug nuts.
3. Lower the vehicle to the ground by turning the jack handle counterclockwise.
4. Finish tightening the lug nuts. Push down on the wrench while at the end of the handle for increased leverage. Tighten the lug nuts in a star pattern until each nut has been tightened twice. The correct tightness of each lug nut is 110 ft/lbs (150 N·m). If in doubt about the correct tightness, have them checked with a torque wrench by your authorized dealer or service station.
5. After 25 miles (40 km) check the lug nut torque with a torque wrench to ensure that all lug nuts are properly seated against the wheel.

CAUTION!

- Do not attempt to raise the vehicle by jacking on locations other than those indicated in the Jacking Instructions for this vehicle.
- Be sure to mount the spare tire with the valve stem facing outward. The vehicle could be damaged if the spare tire is mounted incorrectly.

WARNING!

- Do not attempt to change a tire on the side of the vehicle close to moving traffic. Pull far enough off the road to avoid the danger of being hit when operating the jack or changing the wheel.
- Being under a jacked-up vehicle is dangerous. The vehicle could slip off the jack and fall on you. You could be crushed. Never put any part of your body under a vehicle that is on a jack. If you need to get under a raised vehicle, take it to a service center where it can be raised on a lift.
- Never start or run the engine while the vehicle is on a jack.
- The jack is designed to be used as a tool for changing tires only. The jack should not be used to lift the vehicle for service purposes. The vehicle should be jacked on a firm level surface only. Avoid ice or slippery areas.
- Always park on a firm, level surface as far from the edge of the roadway as possible before raising the vehicle.
- Turn on the Hazard Warning flasher.
- Block the wheel diagonally opposite the wheel to be raised.
- Set the parking brake firmly and set an automatic transmission in PARK.

(Continued)

WHAT TO DO IN EMERGENCIES

WARNING! *(Continued)*

- Do not let anyone sit in the vehicle when it is on a jack.
- Do not get under the vehicle when it is on a jack.
- Only use the jack in the positions indicated and for lifting this vehicle during a tire change.
- If working on or near a roadway, be extremely careful of motor traffic.
- To assure that spare tires, flat or inflated, are securely stowed, spares must be stowed with the valve stem facing the ground.
- Carefully follow these tire changing warnings to help prevent personal injury or damage to your vehicle:
- Raising the vehicle higher than necessary can make the vehicle less stable. It could slip off the jack and hurt someone near it. Raise the vehicle only enough to remove the tire.
- To avoid the risk of forcing the vehicle off the jack, do not tighten the wheel nuts fully until the vehicle has been lowered. Failure to follow this warning may result in personal injury.
- A loose tire or jack, thrown forward in a collision or hard stop could endanger the occupants of the vehicle. Always stow the jack parts and the spare tire in the places provided. Have the deflated (flat) tire repaired or replaced immediately.

BATTERY LOCATION

- The battery in your vehicle is located under the passenger's front seat. Remote battery posts are located on the right side of the engine compartment for jump-starting.

JUMP-STARTING

- If your vehicle has a discharged battery it can be jump-started using a set of jumper cables and a battery in another vehicle or by using a portable battery booster pack.
- Jump-starting can be dangerous if done improperly so please follow the procedures in this section carefully.

NOTE: When using a portable battery booster pack follow the manufacturer's operating instructions and precautions.

WHAT TO DO IN EMERGENCIES

Preparations for Jump-Start

- The battery in your vehicle is located under the passengers front seat. There are remote locations under the hood to assist in jump starting.
- Set the parking brake, shift the automatic transmission into PARK and turn the ignition to LOCK.
- Turn off the heater, radio, and all unnecessary electrical accessories.
- Remove the protective cover over the remote positive (+) battery post. Pull upward on the cover to remove it.



- If using another vehicle to jump-start the battery, park the vehicle within the jumper cables reach, set the parking brake and make sure the ignition is OFF.

Jump-Starting Procedure

- Connect the positive (+) end of the jumper cable to the remote positive (+) post of the discharged vehicle.
- Connect the opposite end of the positive (+) jumper cable to the positive (+) post of the booster battery.
- Connect the negative end (-) of the jumper cable to the negative (-) post of the booster battery.
- Connect the opposite end of the negative (-) jumper cable to the remote negative (-) post of the vehicle with the discharged battery.
- Start the engine in the vehicle that has the booster battery, let the engine idle a few minutes, and then start the engine in the vehicle with the discharged battery.

Once the engine is started, remove the jumper cables in the reverse sequence:

- Disconnect the negative (-) jumper cable from the remote negative (-) post of the vehicle with the discharged battery.
- Disconnect the negative end (-) of the jumper cable from the negative (-) post of the booster battery.
- Disconnect the opposite end of the positive (+) jumper cable from the positive (+) post of the booster battery.
- Disconnect the positive (+) end of the jumper cable from the remote positive (+) post of the discharged vehicle.
- Reinstall the protective cover over the remote positive (+) battery post of the discharged vehicle.

WHAT TO DO IN EMERGENCIES

- If frequent jump-starting is required to start your vehicle you should have the battery and charging system inspected at your authorized dealer.

CAUTION!

- Do not use a portable battery booster pack or any other booster source with a system voltage greater than 12 Volts or damage to the battery, starter motor, alternator or electrical system may occur.
- Failure to follow these procedures could result in damage to the charging system of the booster vehicle or the discharged vehicle.
- Accessories that can be plugged into the vehicle power outlets draw power from the vehicle's battery, even when not in use (i.e., cellular phones, etc.). Eventually, if plugged in long enough, the vehicle's battery will discharge sufficiently to degrade battery life and/or prevent the engine from starting.

WARNING!

- When temperatures are below the freezing point, electrolyte in a discharged battery may freeze. Do not attempt jump-starting because the battery could rupture or explode and cause personal injury. Battery temperature must be brought above freezing point before attempting a jump-start.
- Take care to avoid the radiator cooling fan whenever the hood is raised. It can start anytime the ignition switch is on. You can be injured by moving fan blades.
- Remove any metal jewelry, such as watch bands or bracelets, that might make an inadvertent electrical contact. You could be severely injured.
- Batteries contain sulfuric acid that can burn your skin or eyes and generate hydrogen gas which is flammable and explosive. Keep open flames or sparks away from the battery.
- Do not allow vehicles to touch each other as this could establish a ground connection and personal injury could result.
- Failure to follow this procedure could result in personal injury or property damage due to battery explosion.
- Do not connect the cable to the negative post (-) of the discharged battery. The resulting electrical spark could cause the battery to explode and could result in personal injury.

WHAT TO DO IN EMERGENCIES

EMERGENCY TOW HOOKS

- If your vehicle is equipped with tow hooks, they are mounted in the front and the rear.

NOTE: For off-road recovery, it is recommended to use both of the front tow hooks to minimize the risk of damage to the vehicle.

CAUTION!

Tow hooks are for emergency use only, to rescue a vehicle stranded off-road. Do not use tow hooks for tow truck hookup or highway towing. You could damage your vehicle. Tow straps are recommended when towing the vehicle; chains may cause vehicle damage.

WARNING!

- Chains are not recommended for freeing a stuck vehicle. Chains may break, causing serious injury or death.
- Stand clear of vehicles when pulling with tow hooks. Tow straps may become disengaged, causing serious injury.

SHIFT LEVER OVERRIDE

- If a malfunction occurs and the shift lever cannot be moved out of the PARK position, you can use the following procedure to temporarily move the shift lever:
 - To access the shift lever override, remove the rubber cupholder liner to the right of the shift lever.
 - Firmly set the parking brake.
 - Turn the ignition switch to the ACC or ON position without starting the engine.
 - Press and maintain firm pressure on the brake pedal.
 - Using a screwdriver or similar tool, press and hold the override tab through the access port on the center console.
 - Move the shift lever into the NEUTRAL position.
 - The vehicle may then be started in NEUTRAL.
 - Reinstall the override cover.

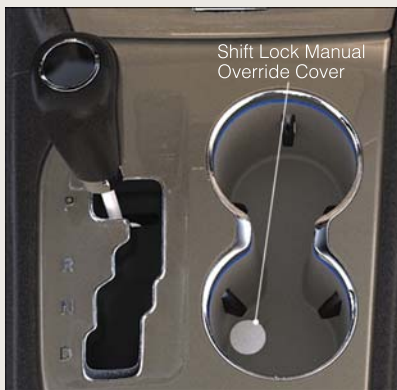

WHAT TO DO IN EMERGENCIES

TOWING A DISABLED VEHICLE

Towing Condition	Wheels OFF the Ground	2WD Models	4WD Models
Flat Tow	NONE	<ul style="list-style-type: none"> • Trans in NEUTRAL • 30 mph max(48 km/h) • 15 miles (24 km) max distance 	<ul style="list-style-type: none"> • Trans in PARK • T/case in NEUTRAL • Tow in forward direction
Wheel Lift or Dolly Tow	Front Rear	OK	NO
Flatbed	ALL	BEST METHOD	BEST METHOD

WHAT TO DO IN EMERGENCIES

EVENT DATA RECORDER (EDR)

- This vehicle is equipped with an event data recorder (EDR). The main purpose of an EDR is to record, in certain crash or near crash-like situations, such as an air bag deployment or hitting a road obstacle, data that will assist in understanding how a vehicle's systems performed. The EDR is designed to record data related to vehicle dynamics and safety systems for a short period of time, typically 30 seconds or less. The EDR in this vehicle is designed to record such data as:
 - How various systems in your vehicle were operating;
 - Whether or not the driver and passenger safety belts were buckled/fastened;
 - How far (if at all) the driver was depressing the accelerator and/or brake pedal; and,
 - How fast the vehicle was traveling.
- These data can help provide a better understanding of the circumstances in which crashes and injuries occur.

NOTE: EDR data are recorded by your vehicle only if a non-trivial crash situation occurs; no data are recorded by the EDR under normal driving conditions and no personal data (e.g. name, gender, age, and crash location) are recorded. However, other parties, such as law enforcement, could combine the EDR data with the type of personally identifying data routinely acquired during a crash investigation.

- To read data recorded by an EDR, special equipment is required, and access to the vehicle or the EDR is needed. In addition to the vehicle manufacturer, other parties such as law enforcement, that have the special equipment, can read the information if they have access to the vehicle or the EDR.

MAINTAINING YOUR VEHICLE

OPENING THE HOOD

- Pull the hood release lever located below the steering wheel at the base of the instrument panel.
- Reach into the opening beneath the center of the hood and move the safety latch lever while lifting the hood at the same time.



WARNING!

Be sure the hood is fully latched before driving your vehicle. If the hood is not fully latched, it could open when the vehicle is in motion and block your vision. Failure to follow this warning could result in serious injury or death.

FUEL DOOR RELEASE

- The fuel door release button is located on the instrument panel below the headlight switch.
- Push the button once and release to open the fuel door.



MAINTAINING YOUR VEHICLE

Fuel Door Emergency Release

- To manually open the fuel door, remove the storage bin located in the rear cargo area and pull the release cable located in the storage bin opening.



Storage Bin Removal

- Push down on inboard edge. This will pop up outboard edge.
- Grab popped up outboard edge with other hand to disengage snaps.
- Remove storage bin.

MAINTAINING YOUR VEHICLE

ENGINE COMPARTMENT

3.6L ENGINE

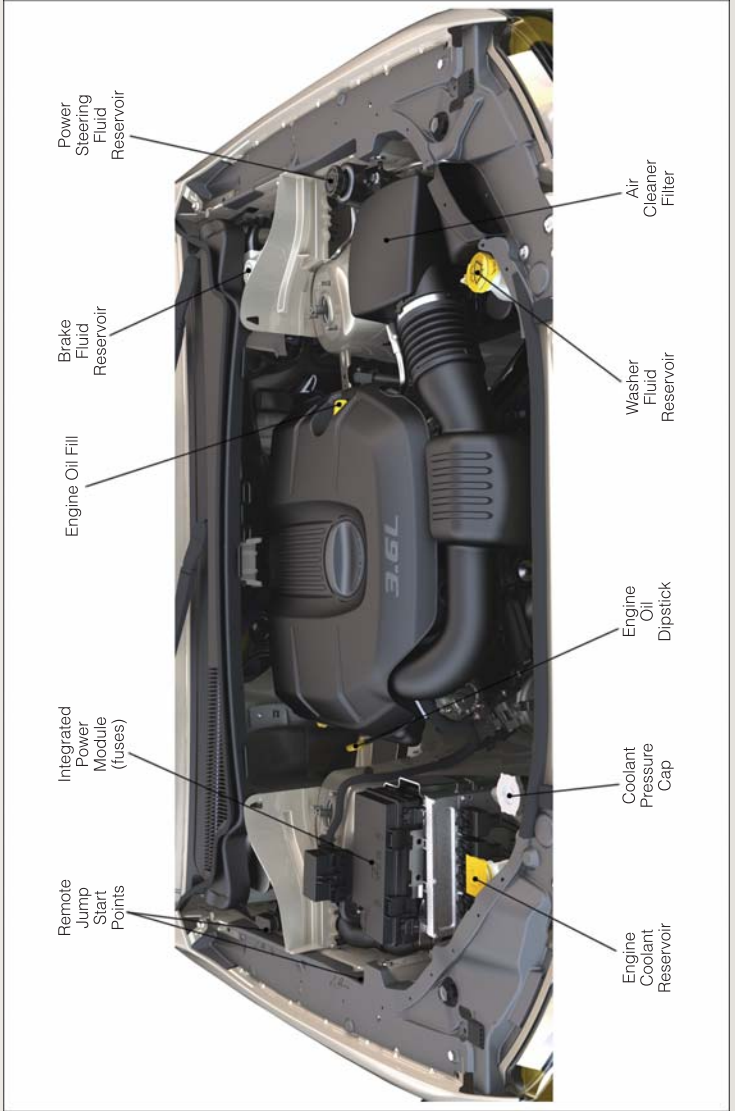

MAINTAINING YOUR VEHICLE

5.7L Engine



MAINTAINING YOUR VEHICLE

6.4L ENGINE

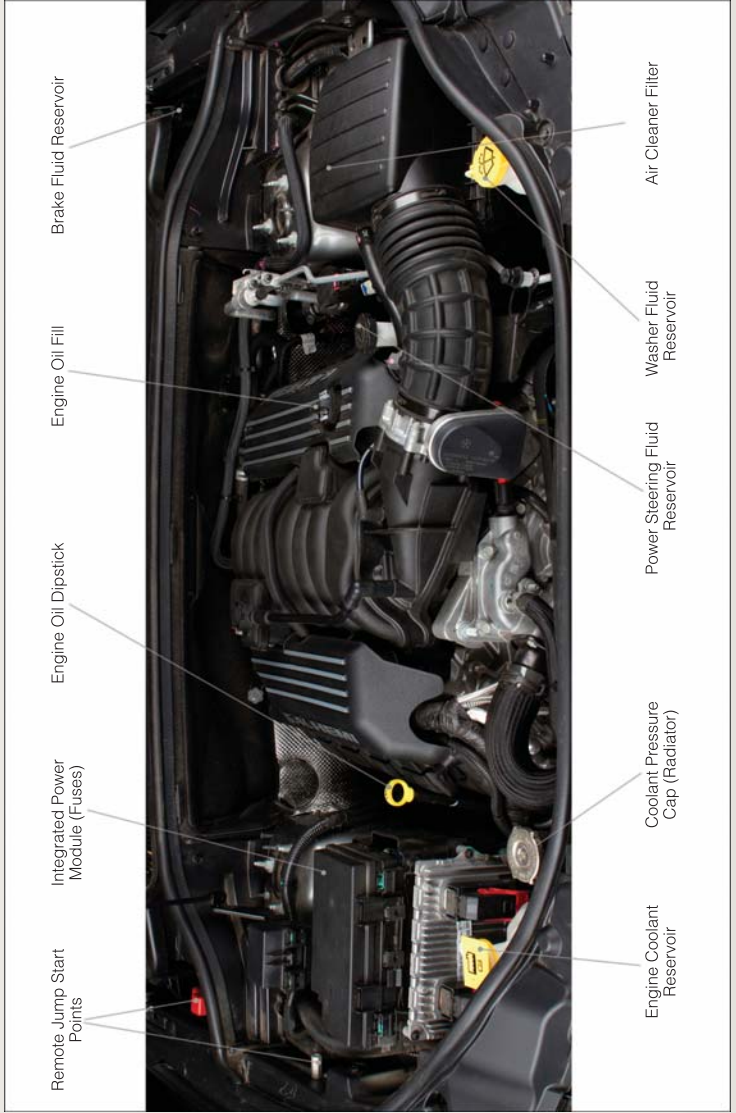

MAINTAINING YOUR VEHICLE

FLUIDS AND CAPACITIES

Component	Fluid, Lubricant, or Genuine Part	Capacities
3.6L Engine	MOPAR® Engine Coolant/ Antifreeze 5-Year/100,000 Mile Formula or equivalent	10.4 Quarts (9.9 Liters)
5.7 Liter Engine - Without Trailer Tow Package	MOPAR® Engine Coolant/ Antifreeze 5-Year/100,000 Mile Formula or equivalent	15.4 Quarts (14.6 Liters)
5.7 Liter Engine - With Trailer Tow Package.	MOPAR® Engine Coolant/ Antifreeze 5-Year/100,000 Mile Formula or equivalent	16 Quarts (15.2 Liters)
6.4 Liter Engine	MOPAR® Engine Coolant/ Antifreeze 5-Year/100,000 Mile Formula or equivalent	16 Quarts (15.2 Liters)
Engine Oil with Filter 3.6L	API certified 5W-30 engine oil, meeting the requirements of Chrysler Material Standard MS-6395. Refer to your oil filler cap for correct SAE grade.	6 Quarts (5.6 Liters)
Engine Oil with Filter 5.7L	API certified 5W-20 engine oil, meeting the requirements of Chrysler Material Standard MS-6395. Refer to your oil filler cap for correct SAE grade.	7 Quarts (6.6 Liters)
Engine Oil with Filter 6.4L	For best performance and maximum protection under all types of operating conditions, the manufacturer only recommends full synthetic engine oils that meet the American Petroleum Institute (API) categories of SM or SM/CF. The manufacturer recommends the use of a full synthetic SAE OW-40 engine oil or equivalent.	7 Quarts (6.6 Liters)
Engine Oil Filter 3.6L, 5.7L, 6.4L	MOPAR® Engine Oil Filter or equivalent.	—
Spark Plug 3.6L	RER8ZWYCB4 (Gap 0.043 in [1.1 mm])	—
Spark Plug 5.7L	LZFR5C-11G (Gap 0.043 in [1.1 mm])	—
Spark Plug 6.4L	LZTR6AP11EG (Gap 0.043 in [1.1 mm])	—
Automatic Transmission	MOPAR® ATF+4® Automatic Transmission Fluid or equivalent licensed ATF+4® product.	—
Transfer Case - 3.6L Engine	Shell Automatic Transmission Fluid 3353 or equivalent.	—

MAINTAINING YOUR VEHICLE

Component	Fluid, Lubricant, or Genuine Part	Capacities
Transfer Case - 5.7L Engine	MOPAR® ATF+4® Automatic Transmission Fluid or equivalent licensed ATF+4® product.	—
Transfer Case - 6.4L Engine	MOPAR® NV146 Transfer Case Fluid or equivalent.	—
Axle Differential (Front/Rear)	MOPAR® Synthetic Gear & Axle Lubricant SAE 75W-140 API-GL5 or equivalent. With friction modifier additive.	—
Axle Differential (Rear) 5.7L Engine With Electronic Limited-Slip Differential (ELSD)	MOPAR® Synthetic Gear & Axle Lubricant SAE 75W-90 (API-GL5) or equivalent.	—
Axle Differential (Rear) 5.7L Engine Without Electronic Limited-Slip Differential (ELSD)	MOPAR® Synthetic Gear & Axle Lubricant SAE 75W-85 (API-GL5) or equivalent.	—
Brake Master Cylinder	MOPAR® DOT 3 and SAE J1703 should be used or equivalent. If DOT 3 is not available, then DOT 4 is acceptable. Use only recommended brake fluids.	—
Power Steering Reservoir - 3.6L Engine	MOPAR® Hydraulic Fluid or equivalent meeting MS-11655, such as Fuchs EG ZH 3044 or Pentosin CHF 11s.	—
Power Steering Reservoir - 5.7L, 6.4L Engine	MOPAR® Power Steering Fluid +4, MOPAR® ATF+4® Automatic Transmission Fluid or equivalent licensed ATF+4® product.	—
Fuel Selection 3.6L, 5.7L	87 Octane acceptable. 89 Octane recommended for 5.7L.	24.6 Gallons (93 Liters) (Approximate)
Fuel Selection 6.4L	Premium Unleaded 91 Octane Only or Higher.	—

E-85 Flexible Fuel - 3.6L Engine Only

CAUTION!

Only vehicles with the E-85 fuel filler door label or a yellow gas cap can operate on E-85.

- Refer to your Owner's Manual on the DVD for further details.

MAINTAINING YOUR VEHICLE

MAINTENANCE CHART

Miles:	8,000	16,000	24,000	32,000	40,000	48,000	56,000	64,000	72,000	80,000	88,000	96,000	104,000
Or Months:	6	12	18	24	30	36	42	48	54	60	66	72	78
Or Kilometers:	13,000	26,000	39,000	52,000	65,000	78,000	91,000	104,000	117,000	130,000	143,000	156,000	169,000
Change the engine oil and engine oil filter.	X	X	X	X	X	X	X	X	X	X	X	X	X
Rotate the tires, rotate at the first sign of irregular wear, even if it occurs before scheduled maintenance.	X	X	X	X	X	X	X	X	X	X	X	X	X
If using your vehicle for any of the following: dusty or off-road conditions. Inspect the engine air cleaner filter; replace if necessary.		X				X				X			
Inspect the brake linings; replace if necessary.		X		X		X		X		X		X	
Inspect the CV joints.			X			X			X			X	
Inspect the exhaust system.		X	X			X			X			X	
Inspect the transfer case fluid and change if necessary.				X				X				X	
Adjust the parking brake on vehicles equipped with four wheel disc brakes.				X				X				X	
Change the automatic transmission fluid and filter if using your vehicle for any of the following: police, taxi, fleet or frequent trailer towing.								X					
Inspect the front and rear axle fluid, change if necessary.			X						X			X	
Inspect front suspension, tie rod ends, and boot seals, for cracks or leaks and all parts for damage, wear, improper looseness or end play; replace if necessary.		X		X		X		X		X		X	
Replace the engine air cleaner.				X				X				X	
Replace the air conditioning filter.		X		X		X		X		X		X	
Replace the spark plugs (5.7L engine)				X				X				X	

MAINTAINING YOUR VEHICLE

Miles:	8,000	16,000	24,000	32,000	40,000	48,000	56,000	64,000	72,000	80,000	88,000	96,000	104,000
Or Months:	6	12	18	24	30	36	42	48	54	60	66	72	78
Or Kilometers:	13,000	26,000	39,000	52,000	65,000	78,000	91,000	104,000	117,000	130,000	143,000	156,000	169,000
Replace the spark plugs (3.6L engine)												X	
Inspect and replace PCV valve.*												X	
Flush and replace the engine coolant at 60 months or 104,000 miles (169,000 km) whichever comes first.										X			
Flush and replace the engine coolant at 104,000 miles (169,000 km) or 60 months whichever comes first.													X

- * This maintenance is recommended by the manufacturer to the owner, but is not required to maintain emissions warranty.
- Refer to the Owner's Manual on the DVD for complete maintenance schedule.

MAINTAINING YOUR VEHICLE

Maintenance Record

	Odometer	Date	Signature, Authorized Service Center
8,000 Miles (13,000 km) or 6 Months			
16,000 Miles (26,000 km) or 12 Months			
24,000 Miles (39,000 km) or 18 Months			
32,000 Miles (52,000 km) or 24 Months			
40,000 Miles (65,000 km) or 30 Months			
48,000 Miles (78,000 km) or 36 Months			
56,000 Miles (91,000 km) or 42 Months			
64,000 Miles (104,000 km) or 48 Months			
72,000 Miles (117,000 km) or 54 Months			
80,000 Miles (130,000 km) or 60 Months			
88,000 Miles (143,000 km) or 66 Months			
96,000 Miles (156,000 km) or 72 Months			
104,000 Miles (169,000 km) or 78 Months			

MAINTAINING YOUR VEHICLE

SRT – MAINTENANCE CHART

Miles:	6,000	12,000	18,000	24,000	30,000	36,000	42,000	48,000	54,000	60,000	66,000	72,000	78,000
Or Months:	6	12	18	24	30	36	42	48	54	60	66	72	78
Or Kilometers:	10,000	20,000	30,000	40,000	50,000	60,000	70,000	80,000	90,000	100,000	110,000	120,000	130,000
Change the engine oil and engine oil filter.	X	X	X	X	X	X	X	X	X	X	X	X	X
If using your vehicle for any of the following: dusty or off-road conditions. Inspect the engine air cleaner filter, replace if necessary.		X		X		X		X				X	
Inspect the brake linings; replace if necessary.		X		X		X		X		X		X	
Inspect the CV joints.		X		X				X				X	
Inspect the exhaust system.		X		X				X				X	
Adjust the parking brake on vehicles equipped with four wheel disc brakes.					X					X			
Change the automatic transmission fluid and filter if using your vehicle for any of the following: police, taxi, fleet or frequent trailer towing.										X			
Inspect the accessory belt(s), replace if necessary.										X			
Drain the transfer case and refill.					X					X			
Inspect front suspension, tie rod ends, and boot seals, for cracks or leaks and all parts for damage, wear, improper looseness or end play; replace if necessary.		X		X		X				X		X	
Replace the engine air cleaner.					X					X			
Replace the air conditioning filter.		X		X		X		X		X		X	
Flush and replace the engine coolant at 60 months if not done at 102,000 miles (170,000 km).										X			

- * This maintenance is recommended by the manufacturer to the owner, but is not required to maintain emissions warranty.
- Refer to the Owner's Manual on the DVD for complete maintenance schedule.

MAINTAINING YOUR VEHICLE

SRT - Maintenance Record

	Odometer	Date	Signature, Authorized Service Center
6,000 Miles (10,000 km) or 6 Months			
12,000 Miles (20,000 km) or 12 Months			
18,000 Miles (30,000 km) or 18 Months			
24,000 Miles (40,000 km) or 24 Months			
30,000 Miles (50,000 km) or 30 Months			
36,000 Miles (60,000 km) or 36 Months			
42,000 Miles (70,000 km) or 42 Months			
48,000 Miles (80,000 km) or 48 Months			
54,000 Miles (90,000 km) or 54 Months			
60,000 Miles (100,000 km) or 60 Months			
66,000 Miles (110,000 km) or 66 Months			
72,000 Miles (120,000 km) or 72 Months			
78,000 Miles (130,000 km) or 78 Months			

MAINTAINING YOUR VEHICLE

FUSES

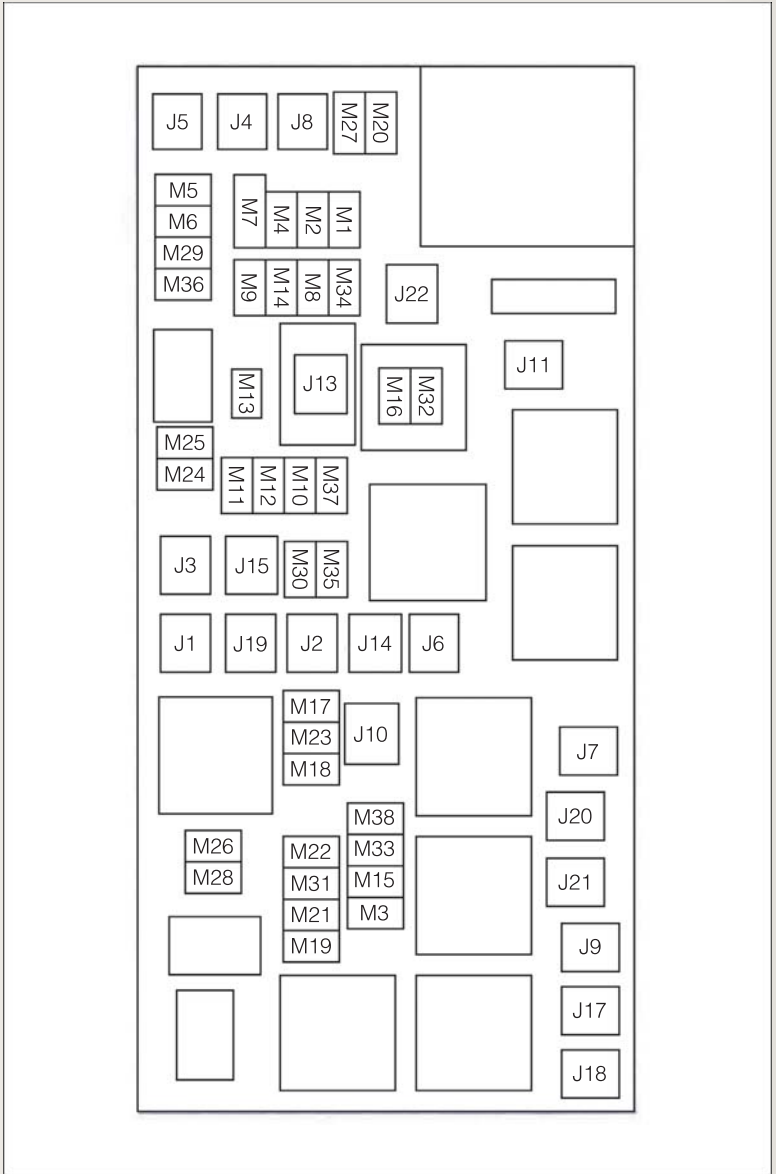

MAINTAINING YOUR VEHICLE

Integrated Power Module (fuses)

The integrated power module is located on the right side of the engine compartment. This center contains cartridge fuses and mini fuses. A description of each fuse and component may be stamped on the inside cover, otherwise the cavity number of each fuse is stamped on the inside cover that corresponds to the following chart.

Cavity	Cartridge Fuse	Mini Fuse	Description
J01	40 Amp Green		Air Suspension
J02	30 Amp Pink		Power Liftgate Module
J03	30 Amp Pink		Trailer Tow
J04	25 Amp Natural		Driver Door Node
J05	25 Amp Natural		Passenger Door Node
J06	40 Amp Green		ABS Pump Feed/ESP
J07	30 Amp Pink		ABS Valve Feed/ESP
J08	40 Amp Green		Power Seat
J09	30 Amp Pink		E-Brake
J10	30 Amp Pink		Headlamp Wash Relay Contact
J11	30 Amp Pink		DTCM
J13	60 Amp Yellow		Streaming Video Module/ VES3 Module/VES2 Module/DISP/DVD
J14	20 Amp Blue		Trailer Tow Lamps/Park Lamps
J15	40 Amp Green		Rear Window Defroster
J17	40 Amp Green		Starter Motor Solenoid Feed
J18	20 Amp Blue		NGC/PCM Transmission Range
J19	60 Amp Yellow		Rad Fan Motor HI/Rad Fan Motor Low
J20	30 Amp Pink		Front Wiper Ground
J21	20 Amp Blue		Front Washer Control/Rear Washer Control
J22	25 Amp Natural		PWR Batt - Sunroof Mod
M1		15 Amp Blue	Sw Stop Switch Lamp Feed
M2		20 Amp Yellow	ELSD/Air Suspension
M3		20 Amp Yellow	Liftgate Unlock/DRL Relay
M4		10 Amp Red	Trailer Tow

MAINTAINING YOUR VEHICLE

Cavity	Cartridge Fuse	Mini Fuse	Description
M5		25 Amp Natural	Inverter
M6		20 Amp Yellow	Power Outlet #1 (Cigar Lighter)/Rain Snr
M7		20 Amp Yellow	Power Outlet #2 (Switchable)
M8		20 Amp Yellow	Front Heated Seat & Steering Wheel
M9		20 Amp Yellow	Rear Heated Seats
M10		20 Amp Yellow	HFM/Vanity Lamp/UGDO Mod
M11		10 Amp Red	HVAC (ATC)
M12		30 Amp Green	Radio/Amplifier
M13		20 Amp Yellow	Main #2 CCN/WIN/ITM/Siren/Multifunction Switch (SCM)
M14		20 Amp Yellow	Back Up Camera (Domestic Only)
M15		20 Amp Yellow	Power Seat Module(s)/ Adaptive Cruise Control/Audio Telematics/DRL Relay/Air Suspension Module/CCN
M16		10 Amp Red	ORC
M17		15 Amp Blue	Lt-Tail/Lic/Park LMP
M18		15 Amp Blue	Rt-Tail/Park/Run LMP
M19		25 Amp Natural	ASD 1 and 2
M20		15 Amp Blue	CCN Interior Lighting Feed/Sw Steering Wheel/ Sw Bank/SCM (EVIC)
M21		20 Amp Yellow	ASD 3
M22		10 Amp Red	Horns (Low/High) - Right
M23		10 Amp Red	Horns (Low/High) - Left
M24		25 Amp Natural	Rear Wiper On
M25		20 Amp Yellow	Fuel Pump Motor Output/ Diesel Lift Pump (Export Only)
M26		10 Amp Red	Driver Door Switch Bank
M27		10 Amp Red	Ignition Switch Feed/WIN/PEM
M28		15 Amp Blue	PCM Feed/TCM
M29		10 Amp Red	CORAX TPM
M30		15 Amp Blue	J1962 Diag Connector

MAINTAINING YOUR VEHICLE

Cavity	Cartridge Fuse	Mini Fuse	Description
M31		20 Amp Yellow	B/U Lamps
M32		10 Amp Red	ORC Feed
M33		10 Amp Red	NGC (PCM)/TCM
M34		10 Amp Red	Park Assist Module/HVAC Module/IR Sensor/Compass Module
M35		15 Amp Blue	LH Rear Parklamps
M36		20 Amp Yellow	Power Outlet
M37		10 Amp Red	ABS/ESP Module/Stoplamp Switch Sensor
M38		25 Amp Natural	All Door Lock & Unlock

CAUTION!

- When installing the integrated power module cover, it is important to ensure the cover is properly positioned and fully latched. Failure to do so may allow water to get into the integrated power module and possibly result in a electrical system failure.
- When replacing a blown fuse, it is important to use only a fuse having the correct amperage rating. The use of a fuse with a rating other than indicated may result in a dangerous electrical system overload. If a properly rated fuse continues to blow, it indicates a problem in the circuit that must be corrected.

TIRE PRESSURES

- Check the inflation pressure of each tire, including the spare tire, at least monthly and inflate to the recommended pressure for your vehicle.
- The tire pressures recommended for your vehicle are found on the “Tire and Loading Information” label located on the driver’s side door opening.

NOTE: Refer to the Owner’s Manual on the DVD for more information regarding tire warnings and instructions.

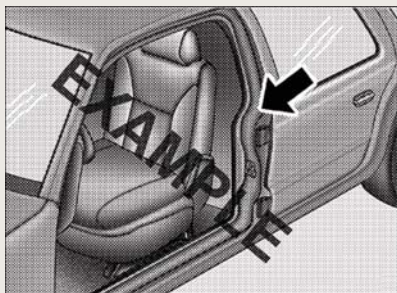

MAINTAINING YOUR VEHICLE

WARNING!

- Overloading of your tires is dangerous. Overloading can cause tire failure, affect vehicle handling, and increase your stopping distance. Use tires of the recommended load capacity for your vehicle. Never overload them.
- Improperly inflated tires are dangerous and can cause collisions. Under-inflation is the leading cause of tire failure and may result in severe cracking, component separation, or “blow out”. Over-inflation reduces a tire’s ability to cushion shock. Objects on the road and chuck holes can cause damage that results in tire failure. Unequal tire pressures can cause steering problems. You could lose control of your vehicle. Over-inflated or under-inflated tires can affect vehicle handling and can fail suddenly, resulting in loss of vehicle control.

WHEEL AND WHEEL TRIM CARE

- All wheels and wheel trim, especially aluminum and chrome plated wheels, should be cleaned regularly with a mild soap and water to prevent corrosion.
- To remove heavy soil and/or excessive brake dust, use MOPAR® Wheel Cleaner or equivalent or select a non-abrasive, non-acidic cleaner.

CAUTION!

Do not use scouring pads, steel wool, a bristle brush, or metal polishes. Do not use oven cleaner. These products may damage the wheel’s protective finish. Avoid automatic car washes that use acidic solutions or harsh brushes that may damage the wheel’s protective finish. Only MOPAR® Wheel Cleaner or equivalent is recommended.

MAINTAINING YOUR VEHICLE

EXTERIOR BULBS

LIGHT BULBS - Exterior	Bulb Number
Tail, Stop, Turn Lamp	3057
Liftgate Backup Lamps	921 (W16W)
Center High-Mounted Stop Lamp (CHMSL)	LED (*)
Fog Lamp - If Equipped	PSX24W
Front Park/Turn Signal	7444NA
Front Side Marker, License Lamp	W5W
Headlamp - High Intensity Discharge (HID)	D1S - Serviced at Authorized Dealer (**)
Headlamp - Low Beam	H11
Headlamp - High Beam	9005

* CHMSL is not serviceable. It is a LED lamp. To replace the LED, the entire CHMSL assembly must be replaced.

** The headlamps are a type of high-voltage discharge tube. High voltage can remain in the circuit even with the headlamp switch off and the Key Fob removed. Because of this, you should not attempt to service a headlamp bulb yourself. If a headlamp bulb fails, take your vehicle to an authorized dealer for service.

CONSUMER ASSISTANCE

CHRYSLER GROUP LLC CUSTOMER CENTER

P.O. Box 21-8004

Auburn Hills, MI 48321-8004

Phone: 1-877-426-5337

CHRYSLER CANADA INC. CUSTOMER CENTER

P.O. Box 1621

Windsor, Ontario N9A 4H6

Phone: 1-800-465-2001 (English)

Phone: 1-800-387-9983 (French)

ASSISTANCE FOR THE HEARING IMPAIRED

- To assist customers who have hearing difficulties, the manufacturer has installed special TDD (Telecommunication Devices for the Deaf) equipment at its customer center. Any hearing or speech impaired customer, who has access to a TDD or a conventional teletypewriter (TTY) in the United States, can communicate with the manufacturer by dialing 1-800-380-CHRY. Canadian residents with hearing difficulties that require assistance can use the special needs relay service offered by Bell Canada. For TTY teletypewriter users, dial 711 and for Voice callers, dial 1-800-855-0511 to connect with a Bell Relay Service operator.

WARNING!

Engine exhaust, some of its constituents, and certain vehicle components contain, or emit, chemicals known to the State of California to cause cancer and birth defects, or other reproductive harm. In addition, certain fluids contained in vehicles and certain products of component wear contain, or emit, chemicals known to the State of California to cause cancer and birth defects, or other reproductive harm.

PUBLICATIONS ORDERING

- **If you are the first registered retail owner of your vehicle**, you may obtain one free printed copy of the Owner's Manual, Warranty Booklet or Radio Manuals on your DVD by calling 1-877-426-5337 (U.S.) or 1-800-387-1143 (Canada) or by contacting your dealer.
- Replacement User Guide kits or DVDs or, if you prefer, additional printed copies of the Owner's Manual, Warranty Booklet or Radio Manuals may be purchased by visiting www.techauthority.com or by calling 1-800-890-4038 (U.S.) or 1-800-387-1143 (Canada). Visa, Master Card, American Express and Discover orders are accepted. If you prefer mailing your order, please call the above numbers for an order form.

CONSUMER ASSISTANCE

NOTE: A street address is required when ordering manuals (no P.O. Boxes).

NOTE:

- The Owner's Manual and User Guide electronic files are also available on the Chrysler, Jeep, Ram Truck and Dodge websites.
- Click on the "For Owners" tab, select "Owner/Service Manuals", then select your desired model year and vehicle from the drop-down lists.

REPORTING SAFETY DEFECTS IN THE 50 UNITED STATES AND WASHINGTON, D.C.

- If you believe that your vehicle has a defect that could cause a collision or cause injury or death, you should immediately inform the National Highway Traffic Safety Administration (NHTSA) in addition to notifying the manufacturer.
- If NHTSA receives similar complaints, it may open an investigation, and if it finds that a safety defect exists in a group of vehicles, it may order a recall and remedy campaign. However, NHTSA cannot become involved in individual problems between you, your authorized dealer, and the manufacturer.
- To contact NHTSA, you may either call the Auto Safety Hotline toll free at 1-888-327-4236 (TTY: 1-800-424-9153), or go to <http://www.safercar.gov>; or write to: Administrator, NHTSA, 1200 New Jersey Avenue, SE., West Building, Washington, D.C. 20590. You can also obtain other information about motor vehicle safety from <http://www.safercar.gov>.

In Canada

- If you believe that your vehicle has a safety defect, you should contact the Customer Service Department immediately. Canadian customers who wish to report a safety defect to the Canadian government should contact Transport Canada, Motor Vehicle Defect Investigations and Recalls at 1-800-333-0510 or go to <http://www.tc.gc.ca/roadsafety/>
- French Canadian customers who wish to report a safety defect to the Canadian government should contact Transport Canada, Motor Vehicle Defect Investigations and Recalls at 1-800-333-0510 or go to <http://www.tc.gc.ca/securiteroutiere/>

MOPAR ACCESSORIES

AUTHENTIC ACCESSORIES BY MOPAR®

- The following highlights just some of the many Authentic Jeep Accessories by Mopar featuring a fit, finish, and functionality specifically for your Jeep Grand Cherokee.
- In choosing Authentic Accessories you gain far more than expressive style, premium protection, or extreme entertainment, you also benefit from enhancing your vehicle with accessories that have been thoroughly tested and factory-approved.
- For the full line of Authentic Jeep Accessories by Mopar, visit your local Jeep dealership or online at mopar.com.

EXTERIOR:

- Molded Running Boards
- Front End Cover
- Wheels
- Black Tubular Side Steps
- Chrome Front Air Deflector
- Skid Plates
- Hitch Receiver
- Chrome Tubular Side Steps
- Molded Splash Guards
- Tow Hooks
- Chrome Accents

INTERIOR:

- Premium Carpet Floor Mats
- Slush Mats
- Heated Seats
- Door Sill Guards
- Katzkin Leather Interiors
- Ambient Footwell Lighting
- Molded Cargo Tray
- Bright Pedal Kit

ELECTRONICS:

- Portable Navigation Systems
- iPod® Adapter
- Remote Start
- Uconnect™ Web (WiFi)
- Radio Upgrades
- Rear View Camera
- Electronic Vehicle Tracking System
- Park Distance Sensors

CARRIERS:

- Hitch-mount Bike Carrier
- Roof Mount Ski and Snowboard Carrier
- Sport Utility Bars
- Roof Box Cargo Carrier
- Roof Mount Water Sports Carrier
- Roof Mount Bike Carrier
- Roof Top Cargo Basket

iPod® is a registered trademark of Apple, Inc.

INDEX

- Adaptive Cruise Control (ACC)
(Cruise Control) 31
- Air Conditioning 35,36
- Air Suspension 87
- Airbag 17
- Airbag Light 101
- Alarm, Panic 10
- Anti-Lock Brake System
(ABS) 100
- Arming Theft System
(Security Alarm) 16
- Audio Settings . . . 44,45,46,48,51,60
- Automatic Dimming Mirror 30
- Automatic Headlights 28
- Automatic Temperature Control
(ATC) 36
- Automatic Transmission
 - Autostick 94
 - Fluid Type 120
- Autostick 94
- Auxiliary Audio/Video
 - Input Jacks 78
- Axle Fluid 120,121
- Axle Lubrication (Axle Fluid) . . . 121

- Back-Up Camera 37
- Battery
 - Charging System Light 100
- Belts, Seat 16
- Blind Spot Monitoring 38
- Brake Fluid 120,121
- Brake System
 - Warning Light 99
- Break-In Recommendations,
New Vehicle 27
- Bulb Replacement 132
- Button, Start/Stop Removal . . 10,14

- Calibration, Compass 79
- Change Oil Indicator 101
- Changing A Flat Tire 103
- Charging System Light 100
- Check Engine Light (Malfunction
Indicator Light) 100
- Child Restraint 18
- Child Restraint Tether Anchors . . 18
- Climate Control 35,36
- Clock Setting 44,46,49,58

- Command View Skylights 40
- Compass Calibration 79
- Cooling System
 - Coolant Capacity 120
- Cruise Control
(Speed Control) 30
- Cruise Light 30
- Customer Assistance 133

- Defects, Reporting 134
- Defroster, Rear Window 35
- Defroster, Windshield 35
- Dimmer Control 28
- Dimmer Switch, Headlight 28
- Disarming, Theft System 16

- E-85 Fuel 121
- ECO 79
- Electronic Range Select (ERS) . . 34
- Electronic Speed Control
(Cruise Control) 30
- Electronic Stability Control
(ESC) 100
- Electronic Throttle Control
Warning Light 101
- Electronic Vehicle Information
Center (EVIC) 79,80,96
- Electronics
 - Your Vehicle's Sound System . . 42
- Emergency Key 10
- Emergency, In Case of
 - Jacking 103
 - Overheating 102
- Engine
 - Break-In Recommendations . . . 27
 - Compartment 117
 - Coolant (Antifreeze) 120
 - Malfunction Indicator
(Check Engine) 100
 - Oil 120
 - Oil Filter 120
 - Oil Selection 120
 - Overheating 102
 - Starting 15
 - Stopping 15
- Event Data Recorder 114
- Exterior Lights 132

INDEX

- Flexible Fuel Vehicles 121
- Flipper Glass, Liftgate 38
- Fluid Capacities 120
- Fluids 120
- Fog Lights 28
- Folding Front Passenger Seat . . . 22
- Folding Rear Seat 23
- Four Wheel Drive 85
 - Shifting 86
- Four Wheel Drive Operation . . . 85
 - Shifting into Transfer Case
 - Neutral (N) 86
 - Shifting out of Transfer Case
 - Neutral (N) 86
- Front Heated Seats 24
- Fuel
 - Filler Cap (Gas Cap) 101
 - Filler Door (Gas Cap) 115
 - Filler Door Emergency Release 116
 - Specifications 120,121
- Fuses 127

- Garage Door Opener (HomeLink®) 80
- Gas Cap (Fuel Filler Cap) 101

- Headlights 28
 - Automatic 28
 - Dimmer Switch 28
 - High Beam 30
 - High Beam/Low Beam Select Switch 30
- Heated Mirrors 35,36
- Heated Seats 24
- Heated Steering Wheel 25
- High Beam/Low Beam Select (Dimmer) Switch 30
- Hill Descent Control 89
- Hill Start Assist 89
- HomeLink® (Garage Door Opener) Transmitter 80
- Hood Release 115

- Instrument Cluster 8
 - Indicators 9
- Instrument Cluster Warning Lights 8,98
- Integrated Power Module (Fuses) 128
- Intermittent Wipers (Delay Wipers) 29
- Introduction 3
- Inverter Outlet (115V) 83
- Inverter, Power 83

- iPod®/USB/MP3 Control 71
 - Bluetooth Streaming Audio . . . 77

- Jack Location 104
- Jack Operation 103,105
- Jacking Instructions 105
- Jump Starting 109

- Key Fob 10
- Keyless Enter-N-Go™
 - Lock/Unlock 13
 - Starting/Stopping 15

- Lane Change Assist 29
- LATCH (Lower Anchors and Tether for CHildren) 18
- Liftgate 38
- Liftgate Flipper Glass 38
- Liftgate, Power 10,38
- Light Bulbs 132
- Lights
 - Warning (Instrument Cluster Description) 8

- Maintenance Record 124,126
- Maintenance Schedule 122,125
- Malfunction Indicator Light (Check Engine) 100
- Media Center Radio 44,46
- Memory Seat 21
- Mirrors
 - Automatic Dimming 30
 - Heated 35,36
- MOPAR® Accessories 135

- Navigation 54,63
- New Vehicle Break-In Period . . . 27

INDEX

- Oil Change Indicator 101
- Oil Change Indicator, Reset 101
- Oil Pressure Light 100
- Oil, Engine
 - Capacity 120
- Outlet
 - Power 83
- Overheating, Engine 102

- Panic Alarm 10
- Park Sense System, Rear 37
- Phone (Pairing) 72
- Phone (Uconnect) 72
- Placard, Tire and Loading Information 130
- Power
 - Glass Sunroof 39
 - Inverter 83
 - Lift Gate 10
 - Outlet (Auxiliary Electrical Outlet) 83
 - Seats 20
 - Steering 120,121
 - Tilt/Telescoping Steering Column 26
- Preparation for Jacking 105
- Programmable Electronic Features 80,96

- Quadra-Lift 87
- Quadra-Trac 85

- Radio Operation 48,57
- Rain Sensitive Wiper System 29
- Rear Camera 37
- Rear Cross Path 38
- Rear Heated Seats 24
- Rear Park Sense System 37
- Rear Seat, Folding 23
- Recreational Towing 91
 - Shifting into Transfer Case Neutral (N) 91
- Remote Starting System 12
- Removal, Start/Stop Button 10,14
- Replacement Bulbs 132
- Reporting Safety Defects 134
- Restraints, Child 18

- Roll Over Warning 4

- Seat Belts 16
- Seats 20
 - Adjustment 22
 - Folding Front Passenger 22
 - Heated 24
 - Lumbar Support 21
 - Memory 21
 - Power 20
 - Rear Folding 23
 - Ventilated 24
- Seek Button 45,47
- Selec-Terrain 87
- Setting the Clock 44,46,49,58
- Shift Lever Override 112
- Short Message Service (SMS) 76
- Signals, Turn 29
- SIRIUS Travel Link 69
- SmartBeams 28
- Spare Tire 104
- Spark Plugs 120
- Speed Control
 - Accel/Decel 30
 - Cancel 30
 - Distance Setting (ACC Only) 31
 - Mode Setting (ACC Only) 31
 - Resume 32
- Speed Control (Cruise Control) 30
- Start/Stop Button Removal 10,14
- Starting
 - Remote 12
- Steering
 - Tilt Column 26
 - Wheel, Heated 25
- Steering Wheel Audio Controls 70
- Store Radio Presets 45,47
- Sun Roof 39
- Supplemental Restraint System - Airbag 17

- Temperature Control, Automatic (ATC) 36
- Temperature Gauge, Engine Coolant 102
- Text Messaging 76

INDEX

- Theft Alarm (Security Alarm) . . . 16
- Theft System Arming 16
- Theft System Disarming 16
- Tilt Steering Column 26
- Tires
 - Air Pressure 130
 - Changing 103
 - Jacking 103
 - Pressure Warning Light 98
 - Spare Tire 104
- Tow Hooks, Emergency 112
- Tow/Haul 91
- Towing 90
 - 24-Hour Towing Assistance . . . 98
 - Disabled Vehicle 113
 - Recreational 91
- Towing Vehicle Behind a
 - Motorhome 91
- Trailer Towing
 - Trailer and Tongue Weight . . . 90
- Trailer Weight 90
- Transfer Case
 - Fluid 120,121
- Transmission
 - Fluid 120
- Turn Signals 29
- Uconnect™ Phone 72
- Uconnect™ Voice Command . . . 75
- Ventilated Seats 24
- Video Entertainment System™
(Rear Seat Video System) 77
- Voice Commands 75
- Warning Lights 98
- Warning, Roll Over 4
- Washer
 - Rear 30
- Washers, Windshield 29
- Wheel and Wheel Trim Care . . . 131
- Wind Buffeting 41
- Windshield Washers 29
- Windshield Wipers 29
- Wiper, Rear 30
- Wipers, Intermittent 29
- Wipers, Rain Sensitive 29

FAQ (How To?)

FREQUENTLY ASKED QUESTIONS

GETTING STARTED

- How do I install my LATCH Equipped Child Seat? pg. 18
- How do I program my Front Seat Memory? pg. 21

OPERATING YOUR VEHICLE

- How does the Electronic Range Select (ERS) operate? pg. 34

ELECTRONICS

- Which radio is in my vehicle? pg. 44, 46, 48, 57
- How do I activate the Audio Jack? pg. 45, 48, 51, 60
- How do I set the clock on my radio? pg. 44, 46, 49, 58
- How do I use the Navigation feature? pg. 54, 63
- How do I pair my cell phone via Bluetooth® with the UConnect™ Hands-Free Voice Activation System? pg. 72
- How do I use my iPod®? pg. 71
- How do I use my USB port to listen to audio through my touch-screen radio? pg. 71
- What does the ECO message mean on the EVIC display? pg. 79
- How do I configure my Universal Garage Door Opener (HomeLink)? pg. 80

OFF-ROAD CAPABILITIES

- How do I shift into different four-wheel drive selections? pg. 85

UTILITY

- How do I know how much I can tow with my Jeep Grand Cherokee? pg. 90

SRT8

- How do I operate the paddle shifters? pg. 94

WHAT TO DO IN EMERGENCIES

- What do I do if my TPMS warning light is blinking? pg. 98
- How do I change a flat tire? pg. 103
- How do I Jump-Start my vehicle? pg. 109

MAINTAINING YOUR VEHICLE

- Where is my Fuse Block located? pg. 127
- What type of oil do I use? pg. 120
- How often should I change my engine's oil? pg. 122
- What should my tire pressure be set at? pg. 130

NOTES

NOTES

This guide has been prepared to help you get quickly acquainted with your new Jeep and to provide a convenient reference source for common questions. However, it is not a substitute for your Owner's Manual.

For complete operational instructions, maintenance procedures and important safety messages, please consult your Owner's Manual, Navigation/Media Center Manuals and other Warning Labels in your vehicle.

Not all features shown in this guide may apply to your vehicle. For additional information on accessories to help personalize your vehicle, visit www.mopar.com or your local Jeep dealer.

Driving and Alcohol:

Drunken driving is one of the most frequent causes of collisions. Your driving ability can be seriously impaired with blood alcohol levels far below the legal minimum. If you are drinking, don't drive. Ride with a designated non-drinking driver, call a cab, a friend, or use public transportation.

WARNING!

Driving after drinking can lead to a collision. Your perceptions are less sharp, your reflexes are slower, and your judgment is impaired when you have been drinking. Never drink and then drive.

Download a FREE electronic copy
of the Owner's Manual or Warranty
Booklet by visiting the For Owners tab at:
www.Jeep.com (U.S.) or
www.Jeep.ca (Canada).

**Download a free Vehicle
Information App** by visiting your
application store, Keyword (Jeep), or
scanning the Microsoft Tag. To put
Microsoft Tags to work for you, use your
mobile phone's browser or App store to
download a Microsoft Tag reader, like the
free one at www.gettag.mobi. Then
follow the directions to scan the code.



12WK741-926-AA
Grand Cherokee
Fourth Edition
User Guide



Jeep.com