



NUMBER: 05-002-15

GROUP: Brakes

DATE: April 24, 2015

This bulletin is supplied as technical information only and is not an authorization for repair. No part of this publication may be reproduced, stored in a retrieval system, or transmitted, in any form or by any means, electronic, mechanical, photocopying, or otherwise, without written permission of FCA US LLC.

SUBJECT:

Front Brake Squeak/Squeal Noise

OVERVIEW:

This bulletin involves replacing the front brake caliper guide pin bushings.

MODELS:

| | | |
|-------------|------|---------------------|
| 2011 - 2015 | (WK) | Jeep Grand Cherokee |
| 2011 - 2015 | (WD) | Dodge Durango |

NOTE: This bulletin applies to vehicles built on or before December 1, 2015 (MDH 1201XX) equipped with Anti-Lock 4-Wheel Disc Brakes (sales code BRY) or Anti-Lock 4-Wheel Disc HD Brakes (sales code BR6).

SYMPTOM/CONDITION:

The customer may describe a front brake squeak/squeal noise at cold temperatures or with cold brakes after sitting. Noise is most prevalent during a low-speed stop with light brake pedal effort.

DIAGNOSIS:

If the customer describes the symptom, perform the Repair Procedure.

PARTS REQUIRED:

| Qty. | Part No. | Description |
|------|------------|---------------------|
| 2 | 68138845AA | PIN KIT, Disc Brake |

REPAIR PROCEDURE:

1. Raise and support the vehicle. Refer to the detailed service procedures available in DealerCONNECT> TechCONNECT under: Service Info> 04 - Vehicle Quick Reference> Hoisting - Standard Procedure.
2. Remove the front wheel and tire assemblies.

3. Remove the brake caliper tension clip (1) by pressing rearward on the front of the clip (2) while pulling the clip out (3) from the caliper (Fig. 1).

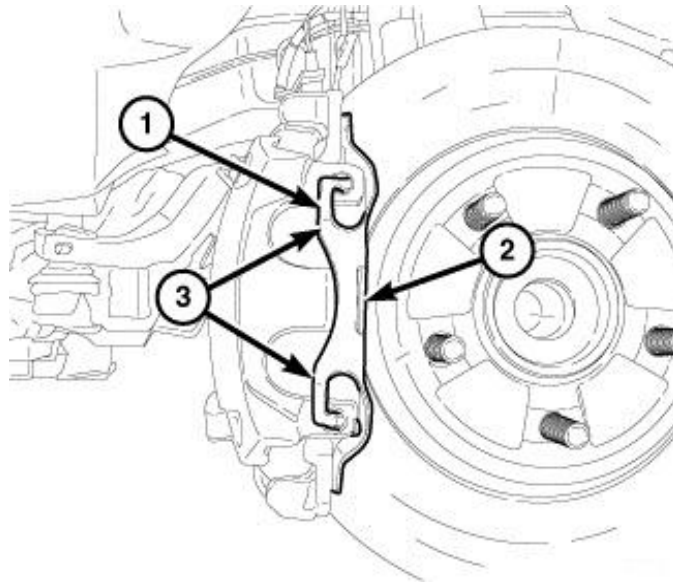

Fig. 1 Tension Clip Removal

- 1 - Tension Clip Retainer
 - 2 - Tension Clip Front
 - 3 - Tension Clip Rear
-

4. Remove and discard the dust shields covering the brake caliper guide pins (1) (Fig. 2).
5. Loosen the brake caliper guide pins (1) (Fig. 2).
6. Remove the brake caliper (2) from the adapter (Fig. 2).

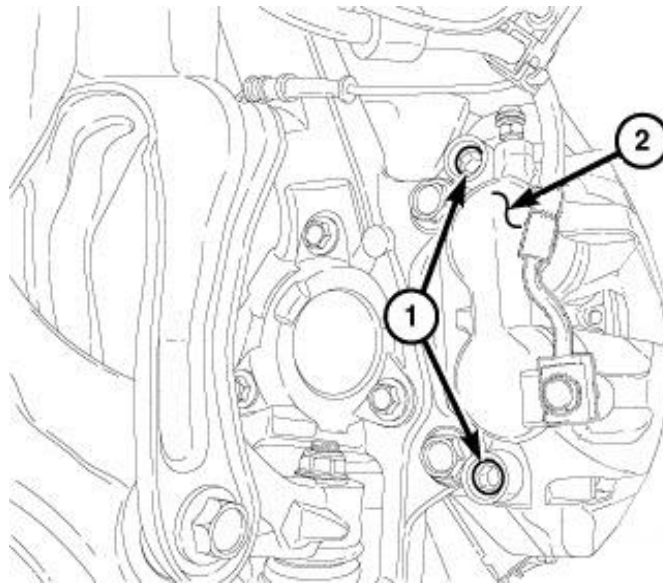

Fig. 2 Brake Caliper Removal

1 - Brake Caliper Guide Pins

2 - Brake Caliper

CAUTION: Support the brake caliper to prevent weight or stress from being applied to the brake hose or damage to the brake hose may result.

7. Push the brake caliper guide pins (1) out of the bushings (2) and discard the guide pins (Fig. 3).
8. Remove the bushings (2) from the brake caliper (3) and discard the bushings (Fig. 3).

NOTE: The stiffened bushing with the white insert goes in the trailing (top) location on the caliper. DO NOT add grease to the guide pins or bushings.

NOTE: Use soapy water on the bushings exterior surface to ease installation. It may also be necessary to also use a blunt plastic trim stick or equivalent to assist with starting the bushing into the caliper guide pin hole.

9. Install the NEW bushings (2) to the brake caliper (3). The bushing is fully inserted when the bushing retention lips (4) are visible and properly seated on both sides of the caliper guide pin hole (Fig. 3).
10. Install the NEW guide pins (1) into the bushings (Fig. 3).

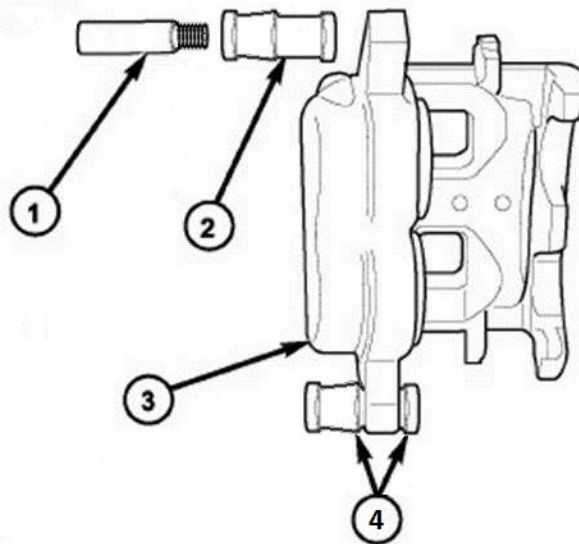

Fig. 3 Brake Caliper Guide Pins And Bushings

- 1 - Guide Pin
 - 2 - Bushing
 - 3 - Brake Caliper
 - 4 - Bushing Retention Lips
-

NOTE: Brake caliper slide bolts (guide pins) should be free from debris.

11. Position the brake caliper (2) and tighten the NEW brake caliper guide pins (1) to 55 N·m (41 ft. lbs.) (Fig. 4).
12. Install the NEW dust shields covering the brake caliper guide pins (1) (Fig. 4).

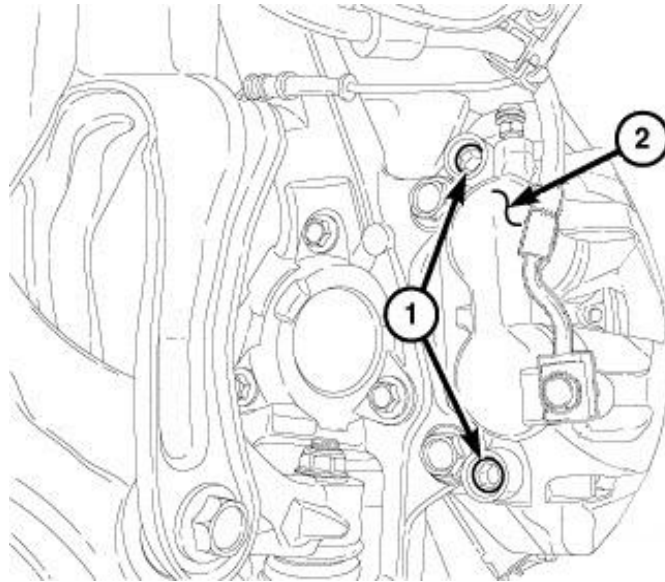

Fig. 4 Brake Caliper Installation

- 1 - Brake Caliper Guide Pins
 - 2 - Brake Caliper
-

13. Install the brake caliper tension clip (1) (Fig. 5).

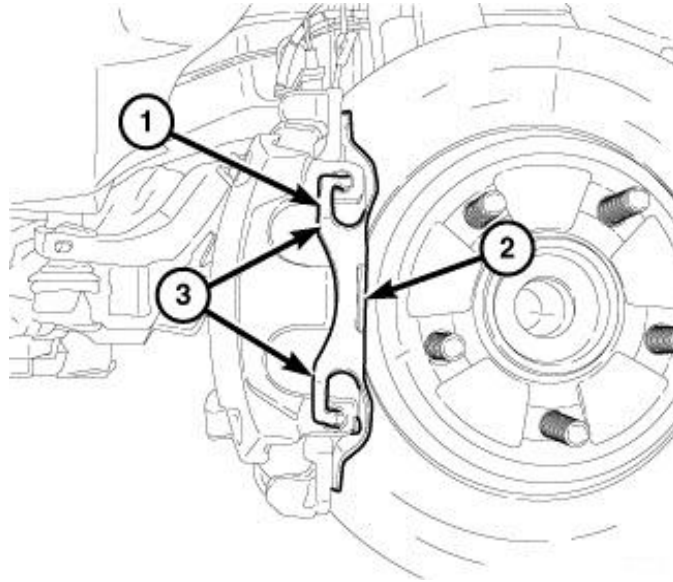

Fig. 5 Tension Clip Installation

- 1 - Tension Clip Retainer
- 2 - Tension Clip Front
- 3 - Tension Clip Rear

14. Install the wheel and tire assembly. Refer to the detailed service procedures available in DealerCONNECT> TechCONNECT under: Service Info> 22 - Tires and Wheels> Wheels> Standard Procedure.

15. Lower the vehicle.

16. Pump the brake pedal until the brake caliper pistons and brake pads are seated and a firm brake pedal is obtained.

POLICY:

Reimbursable within the provisions of the warranty.

TIME ALLOWANCE:

| Labor Operation No: | Description | Skill Category | Amount |
|---------------------|---|---------------------|----------|
| 05-81-20-90 | Pins And Bushings, Front Brake Caliper Guide - Replace (1 - Semi-Skilled) | 4 - Chassis Systems | 0.6 Hrs. |

FAILURE CODE:

| | |
|----|----------------|
| ZZ | Service Action |
|----|----------------|